

SERVICE ENCLOSURE WIRING DIAGRAM

METERED PER UTILITY REQUIREMENTS

TYPE III-AF SERVICE EQUIPMENT SCHEDULE		
	COMPONENT	NAME PLATE DESCRIPTION
①	NEUTRAL LUG	
②	LANDING LUG	
③	TEST BYPASS FACILITIES	
④	METER SOCKET AND SUPPORT	
⑤	TERMINAL BLOCKS	
⑥	SOLID NEUTRAL BUS	
⑦	GROUND BUS	
⑧	GROUND ROD	
⑨	35A MERCURY CONTACTOR	
⑩	PHOTO ELECTRIC UNIT	
⑪	15 AMP SWITCH SPST	LIGHTING TEST SWITCH
⑫	15A,120V,1P,CKT.BKR.	LIGHTING CONTROL
⑬	50A,120V,1P,CKT.BKR.	SIGNALS
⑭	20A,240V,1P,CKT.BKR.	STREET LIGHTS (TRAF.SIG.)
⑮	100A,240V,2P,CKT.BKR.	SERVICE DISCONNECT
⑰	20A,120V,1P,CKT.BKR.	SPARE
⑳	50A,120V,FLANGED RECEPTACLE	
㉑	55A,120V,1P	TRANSFER SWITCH

METER SOCKET  
WIRED FOR  
120/240 OR  
208/240V  
SINGLE PHASE

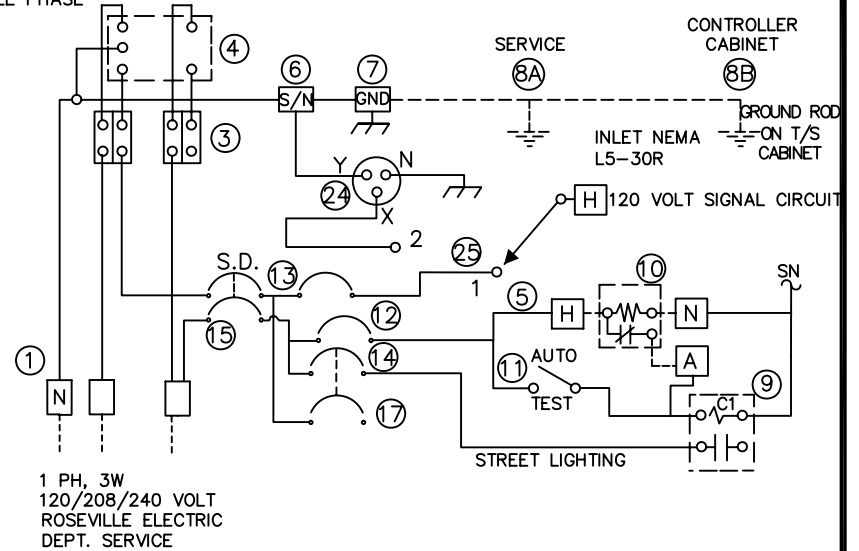

*RHON HERNDON*

RHON HERNDON  
PUBLIC WORKS DIRECTOR



DEPARTMENT OF  
PUBLIC WORKS

TYPICAL SERVICE  
AND  
WIRING SCHEDULE

SCALE: NONE  
REVISED: JANUARY 1, 2013  
DRAWN BY: J MCKINNEY  
APPROVED BY: RHON HERNDON

TS-1

EQUIPMENT SCHEDULE										
STANDARD		SIG. MA (FEET)	LUM. MA (FEET)	VEHICLE SIGNAL MOUNTING		PEDESTRIAN SIGNAL MOUNTING	PPB Ø	ARROW	HPS LUMINAIRE WATTAGE	REMARKS
LOC	TYPE			MAST ARM	POLE					
(A)	61-5-129 *	65'	15'	MAT MAS MAS	SV-1-T	SP-1-CS	-	-	400W	INSTALL EVD AND R73-5 ON SMA. INSTALL IISNS MAST ARM AND CITY SUPPLIED IISNS (Fiddymnt Rd) ON POLE AT 25'.
(B)	PPB POST	-	-	-	-	-	Ø6 Ø8	LEFT RIGHT	-	
(C)	1-B	-	-	-	TV-2-T	SP-1-CS	-	-	-	
(D)	61-5-129 *	65'	15'	MAT MAS	SV-1-T	SP-1-CS	-	-	400W	INSTALL EVA AND R73-5 ON SMA. INSTALL IISNS MAST ARM AND CITY SUPPLIED IISNS (Blue Oaks Blvd) ON POLE AT 25'.
(E)	PPB POST	-	-	-	-	-	Ø2 Ø8	RIGHT LEFT	-	
(F)	1-B	-	-	-	TV-2-T	SP-1-CS	-	-	-	
(G)	61-5-129 *	65'	15'	MAT MAS MAS	SV-1-T	SP-1-CS	-	-	400W	INSTALL EVB AND R73-5 ON SMA. INSTALL IISNS MAST ARM AND CITY SUPPLIED IISNS (Fiddymnt Rd) ON POLE AT 25' MIN. INSTALL WIFI CABLE AND PAN, TILT, ZOOM (PTZ) CAMERA CABLES TO TOP OF POLE WITH 10' SLACK. CITY WILL INSTALL PTZ CAMERA. PEU ATOP THIS POLE.
(H)	PPB POST	-	-	-	-	-	Ø2 Ø4	LEFT RIGHT	-	
(I)	1-B	-	-	-	TV-2-T	SP-1-CS	-	-	-	
(J)	61-5-129 *	65'	15'	MAT MAS	SV-1-T	SP-1-CS	-	-	400W	INSTALL EVC AND R73-5 ON SMA. INSTALL IISNS MAST ARM AND CITY SUPPLIED IISNS (Blue Oaks Blvd) ON POLE AT 25'.
(K)	PPB POST	-	-	-	-	-	Ø4 Ø6	LEFT RIGHT	-	
(L)	1-B	-	-	-	TV-2-T	SP-1-CS	-	-	-	

\* CONTRACTOR SHALL PROVIDE TO THE CITY, ENGINEERING CALCULATIONS FROM THE POLE MANUFACTURER FOR LOADING CONDITIONS IF NOT ALREADY ON FILE WITH THE CITY.



RHON HERNDON  
PUBLIC WORKS DIRECTOR

	DEPARTMENT OF PUBLIC WORKS
TYPICAL POLE AND EQUIPMENT SCHEDULE	
SCALE: NONE REVISED: JANUARY 1, 2010 DRAWN BY: J MCKINNEY APPROVED BY: RHON HERNDON	
TS-2	

ALL TRAFFIC SIGNAL AND SIC CONDUIT SHALL HAVE A DLC TAPED WITH A 5" GREEN BAND AND LABELED WITH "LOCATE".

CONDUCTOR SCHEDULE																									
CONDUCTOR DESIGNATION			NUMBER OF CONDUCTORS																						
CABLE TYPE	STD	PHASE	RUN NUMBER																						
			1	2	3	4	5	6	7	8	9	10	11												
VEH-PED 12CSC	(A)	1,6,4,4P,6P / 4P,6P					2	2						2	2										
	(B)	5,4,0LA,4P,6P / 4P,6P			2	2	2	2			2	2													
	(C)	1,4,2P,4P / 2P		2	1					2	1			2	1										
	(D)	/ 4P	2	1					1	1	1														
	(E)	2,5,2P /												2	2										
	(F)	/ 2P,4P				2		2				2			2										
PPB 3CSC	(G)	4,0LA,4P /		2		2			2	2															
	(H)	2,5,2P / 2P		2	1			2	1				2	1											
TOTAL CABLES 12/3 CONDUCTORS			2	1	6	2	2	4	2	2	6	8	2	2	2	1	4	4	4	4	2	4	1	6	5
#14	PEU								3	3	3	3													
#12	IISNS		2	2	2	2	2	2	2	2	2	2										2			
#8	LUMINAIRES		2	2	2	2	2	2	4	4	4											2			
	GROUND +		1	1	1	1	1	1	1	1	1	1	1	1	1	1	1	1	1	1	1	1	1	1	1
	TRACER TAPE ++		1	1	1	1	1	1	1	1	1	1	1	1	1	1	1	1	1	1	1	1	1	1	1
DLC	ø1			4	4	4	4	4	4	4	4	4	4												
	ø2													4	5										
	ø3					4	4	4	4	4	4	4													
	ø4								7	7	7	7	7	7	7								7	7	
	ø5									4	4	4	4												
	ø6			5	5	5	5	5	5	5	5	5	5	5	5										
	ø7									4	4	4	4	4	4	4							4	4	
	ø8						7	7	7	7	7	7	7	7	7										
	TOTAL		-	9	9	20	20	31	35	39	40	40	11	11											
EVP			1	1	2	2	3	4	4	4	4	4	1												
PTZ CCTV CAT6	⊙							2	2	2	2	2													
PTZ CCTV POWER CABLE	*							1	1	1	1	1													
RSU CAT6	⊙							1	1	1	1	1													
	CONDUIT SIZE		2"	3"	2-3"	2-3"	2-3"	3-3"	3-3"	3-3"	3-3"	3-3"	3"	3"											
	PERCENT FILL		25	22	15	21	26	25	27	28	26	24	15												

+ = PROVIDE 1 #8 AWG STRANDED COPPER WIRE WITH GREEN THW INSULATION IN EACH CONDUIT.

++ = PROVIDE A DLC TAPED WITH A 5" GREEN BAND AND LABELED WITH "LOCATE" IN EACH CONDUIT.

⊙ = FURNISH AND INSTALL SHIELDED OSP CAT6 CABLES OR PER CITY APPROVED EQUIVALENT LIST. COIL 10 FEET OF SLACK AT TOP OF POLE.

\* = FURNISH AND INSTALL IMSA 14-3/20-1-STR 600V POWER CABLE, COLOR CODE 3/C (BELDEN PART NUMBER 601195 OR CITY APPROVED EQUIVALENT). COIL 10 FEET OF SLACK AT TOP OF POLE.

ALL FIELD WIRING SHALL BE COMPRISED OF MULTIPLE CIRCUIT CONDUCTORS PER THE "CONDUCTOR SIGNAL CABLE REQUIREMENTS" TABLE IN SECTION 86-2.08D OF THE CALTRANS STANDARD SPECIFICATIONS. THERE SHALL BE 3 SPARE CONDUCTORS AT EACH POLE.



RHON HERNDON  
PUBLIC WORKS DIRECTOR



DEPARTMENT OF  
PUBLIC WORKS

TYPICAL CONDUCTOR SCHEDULE

SCALE: NONE  
REVISED: JANUARY 2025  
DRAWN BY: J PASTOR  
APPROVED BY: RHON HERNDON



TESCO TYPE 27-22 SERVICE WITH BATTERY BACK-UP SYSTEM EQUIVALENT (OR APPROVED SERVICE FOUNDATION) SHALL BE 21"(W)X26"(D)X24\*(H) AND LEVEL. REFER TO MANUFACTURERS SPECS FOR ADDITIONAL INFORMATION

17.5' MINIMUM

RETAINING CURB 6" HEIGHT MINIMUM (See 86-2.03 OF THE CITY CONSTRUCTION STANDARDS)

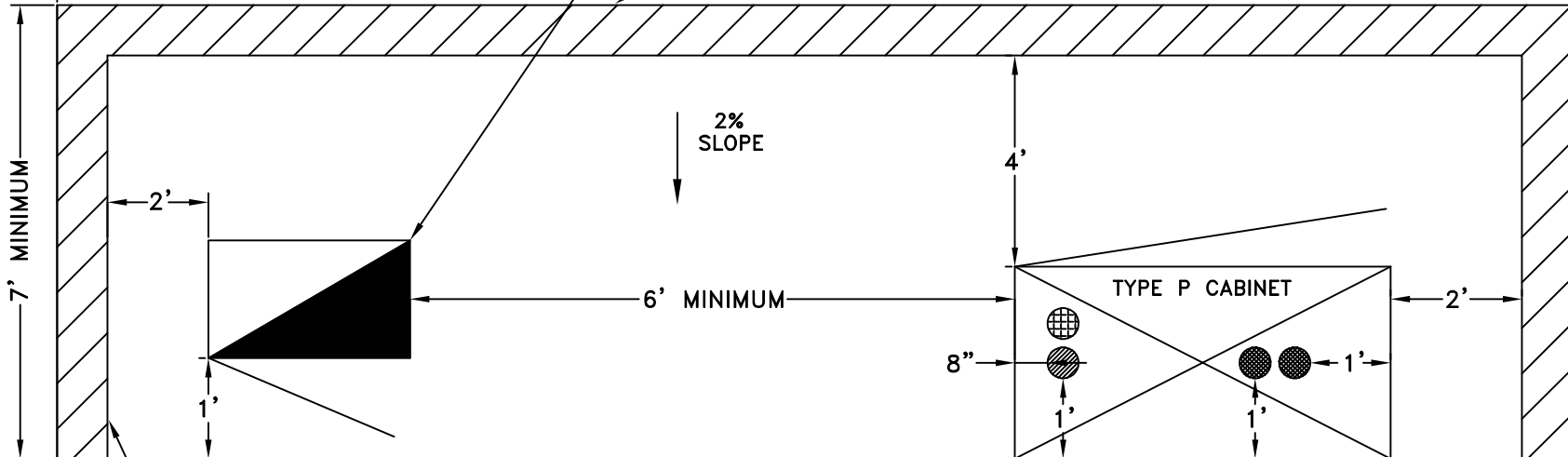

SLOPE TO MATCH EXISTING BACK OF WALK

RETAINING CURB 6" HEIGHT MINIMUM (See 86-2.03 OF THE CITY CONSTRUCTION STANDARDS)

CONTROLLER FOUNDATION SHALL BE 2018 CALTRANS STANDARD PLANS ES-3A

- - 4" SIGNAL
- ⊗ - 3" INTERCONNECT
- ◐ - 2" SERVICE

JASON SHYKOWSKI  
PUBLIC WORKS DIRECTOR

CITY OF **ROSEVILLE** CALIFORNIA  
DEPARTMENT OF PUBLIC WORKS

NEMA 2070 CONTROLLER/SERVICE CABINET PAD DETAIL

SCALE: NONE  
REVISED: JANUARY 2025  
DRAWN BY: R YAKIMCHUK  
APPROVED BY: J CERVANTES

TS-5

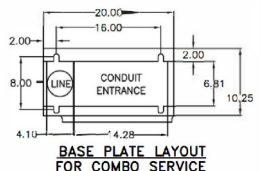

BASE PLATE LAYOUT FOR COMBO SERVICE

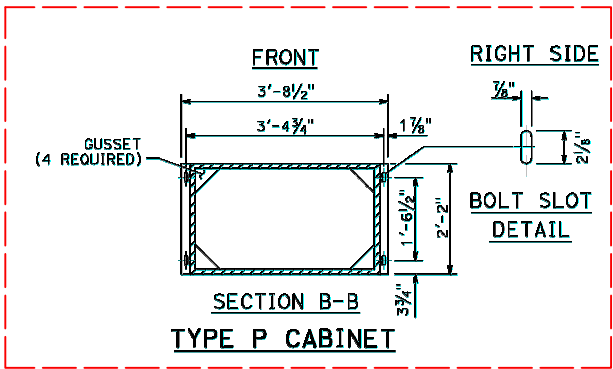

SECTION B-B TYPE P CABINET

\* TOP OF FOUNDATION SHALL BE A MINIMUM OF 4" ABOVE THE CONTROLLER/SERVICE PAD

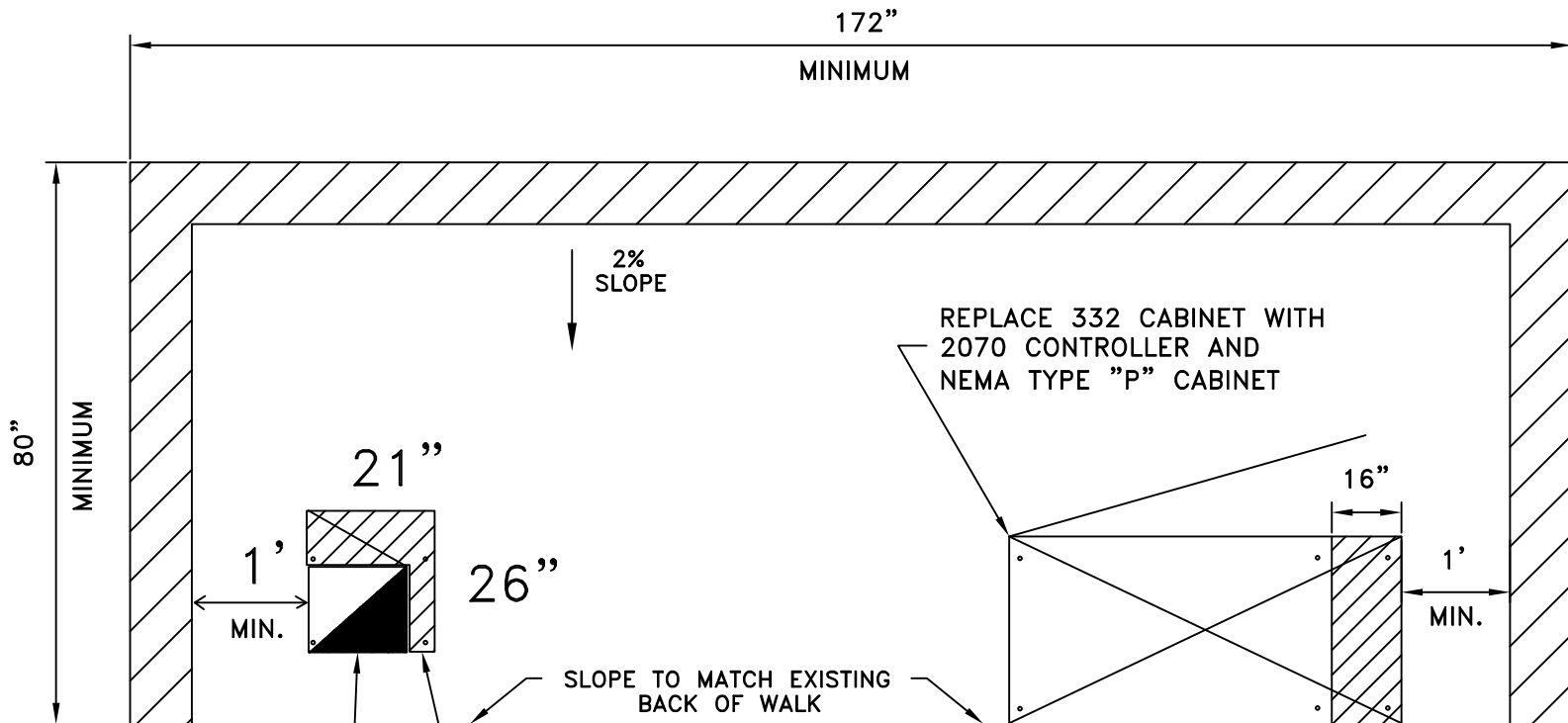

RETAINING CURB 6" HEIGHT MINIMUM (SEE 86-2.03 OF THE CITY CONSTRUCTION STANDARDS)

SERVICE FOUNDATION SHALL BE MODIFIED PER CONSTRUCTION STANDARD DETAIL TS-8. IF (E) ABOVE GROUND FOUNDATION IS GROUTE MATERIAL, REPOUR ENTIRE FOUNDATION PER TS-5.

REPLACE (E) TYPE III-AF SERVICE WITH A (N) TESCO 27-22 SERVICE/ BATTERY BACK-UP SYSTEM OR APPROVED EQUIVALENT WITH PEU (OR APPROVED EQUIVALENT). SERVICE FOUNDATION SHALL BE LEVEL.

CABINET FOUNDATION SHALL BE MODIFIED PER CONSTRUCTION STANDARD DETAIL TS-7. REFER TO CALTRANS STANDARD PLANS ES-3A FOR MORE CABINET INFORMATION. CABINET FOUNDATION SHALL BE LEVEL.

REPLACE 332 CABINET WITH 2070 CONTROLLER AND NEMA TYPE "P" CABINET

ROADWAY/SIDEWALK SIDE

RHON HERNDON  
PUBLIC WORKS DIRECTOR



DEPARTMENT OF PUBLIC WORKS

332 TO TYPE "P" CABINET/SERVICE PAD CONVERSION DETAIL

SCALE: NONE  
REVISED: JANUARY 1, 2025  
DRAWN BY: J MCKINNEY  
APPROVED BY: RHON HERNDON

TS-6

- A= EXISTING 332 CABINET FOUNDATION PER STANDARD PLANS DRAWING ES-3B.
- B= EXISTING PAD AROUND THE 332 CABINET IS TO BE REMOVED AND REPLACED PER CONSTRUCTION STD. DRAWING TS-6 WHEN POSSIBLE.
- C= EXISTING 332 CABINET MOUNTING BOLTS TO BE CUT OFF FLUSH WITH PAD.
- D= INSTALL TWO NEW CABINET BOLTS PER STD. PLANS ES-4A SPACING.
- E= INSTALL NEW FOUNDATION EXTENSION TO ACCOMMODATE TYPE "P" CABINET.
- F= INSTALL A MINIMUM OF (3) 5/8" X 17" METAL DOWELS & TWO PART EPOXY PER SECTION 71, PARAGRAPH 11 OF THE CITY CONSTRUCTION STANDARDS.
- G= SHOULD THE (E) 332 CABINET NOT HAVE A CONDUIT INTO THE SERVICE FOUNDATION, INSTALL ONE 2" C FROM THE NEW 'P' CABINET FOUNDATION TO THE NEW COMBO/SERVICE FOUNDATION.
- H= SHOULD THE (E) 332 CABINET NOT HAVE AN APPROVED GROUND ROD, INSTALL GROUND ROD IN NEW FOUNDATION AREA.

**CAUTION:** LOCATE (E) CONDUITS IN (E) FOUNDATION PRIOR TO DRILLING FOR DOWELS TO AVOID ELECTRICAL SHOCK HAZARD.

- NOTE:** 1) (E) 332 CABINET & 170 CONTROLLER ARE TO REMAIN IN OPERATION WHILE NEW FOUNDATION & PAD ARE POURED. CONVERSION TO THE NEW TYPE "P" CABINET & 2070 CONTROLLER ARE TO OCCUR ONLY AFTER COMPLETION OF ALL CONCRETE WORK, WITH MINIMAL TRAFFIC SIGNAL DOWN TIME.
- 2) THE TYPE "P" CABINET MOUNTING HOLES WILL HAVE TO BE RE-DRILLED ON ONE SIDE TO MATCH (E) BOLT PATTERN ON (E) FOUNDATION SIDE.
- 3) NEW GROUND ROD AND/OR CONDUITS INSTALLED IN NEW FOUNDATION AREA SHALL BE LOCATED AT LEAST 3" INSIDE THE NEW CABINET BOLTS TO AVOID HITTING THE NEW 'P' CABINET WHEN INSTALLED.

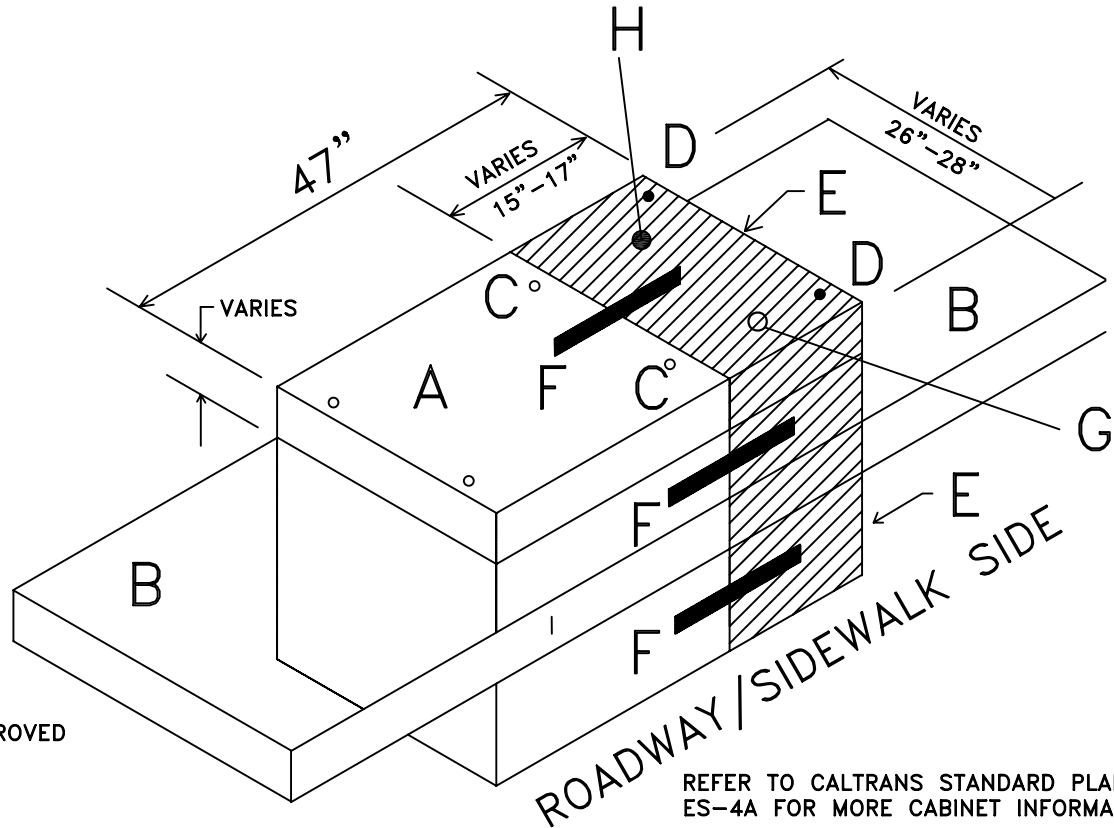

REFER TO CALTRANS STANDARD PLANS ES-4A FOR MORE CABINET INFORMATION

*RHON HERNDON*

RHON HERNDON  
PUBLIC WORKS DIRECTOR

	DEPARTMENT OF PUBLIC WORKS
EXISTING 332 TO TYPE "P" CABINET PAD CONVERSION DETAIL	
SCALE: NONE REVISED: JANUARY 1, 2010 DRAWN BY: J MCKINNEY APPROVED BY: RHON HERNDON	
TS-7	

A= EXISTING TYPE III-AF CABINET FOUNDATION PER STANDARD PLANS DRAWING ES-2D.

B= EXISTING PAD AROUND THE TYPE III-AF SERVICE TO BE REMOVED AND REPLACED PER CONSTRUCTION STANDARD TS-6.

C= EXISTING TYPE III-AF CABINET MOUNTING BOLTS TO BE CUT OFF FLUSH WITH PAD.

D= INSTALL THREE (3) NEW CABINET BOLTS PER TESCO 27/22 PLAN SPACING.

E= INSTALL NEW FOUNDATION EXTENSION TO ACCOMMODATE TESCO 27-22 OR APPROVED EQUIVALENT CABINET.

F= INSTALL A MINIMUM OF (4) 5/8" X 12" METAL DOWELS & TWO PART EPOXY PER SECTION 71, PARAGRAPH 11 OF THE CITY CONSTRUCTION STANDARDS.

G= SHOULD THE (E) SERVICE NOT HAVE A CONDUIT DIRECTLY INTO THE CONTROLLER CABINET, INSTALL ONE 2" C FROM THE NEW SERVICE FOUNDATION TO THE NEW 'P' CABINET FOUNDATION.

**CAUTION:** LOCATE (E) CONDUITS IN (E) FOUNDATION PRIOR TO DRILLING FOR DOWELS TO AVOID ELECTRICAL SHOCK HAZARD.

- NOTE:** 1) (E) TYPE III-AF CABINET & SERVICE ARE TO REMAIN IN OPERATION WHILE NEW FOUNDATION & PAD ARE POURED. CONVERSION TO THE NEW COMBO SERVICE/ BATTERY BACK-UP ARE TO OCCUR ONLY AFTER COMPLETION OF ALL CONCRETE WORK, WITH MINIMAL TRAFFIC SIGNAL DOWN TIME.
- 2) THE COMBO 22-27 CABINET MOUNTING HOLES MAY HAVE TO BE RE-DRILLED ON ONE SIDE OF CABINET TO MATCH (E) BOLT PATTERN ON (E) FOUNDATION SIDE.
- 3) IF (E) ABOVE GROUND FOUNDATION IS GROUTE MATERIAL, REMOVE GROUT AND REPOUR AREA WITH THE NEW FOUNDATION EXTENSION.
- 4) ANY CONDUITS INSTALLED IN NEW PAD DETAIL SHALL BE LOCATED AT LEAST 3" INSIDE THE NEW COMBO/SERVICE BOLTS TO AVOID HITTING THE NEW COMBO/SERVICE CABINET WHEN INSTALLED.

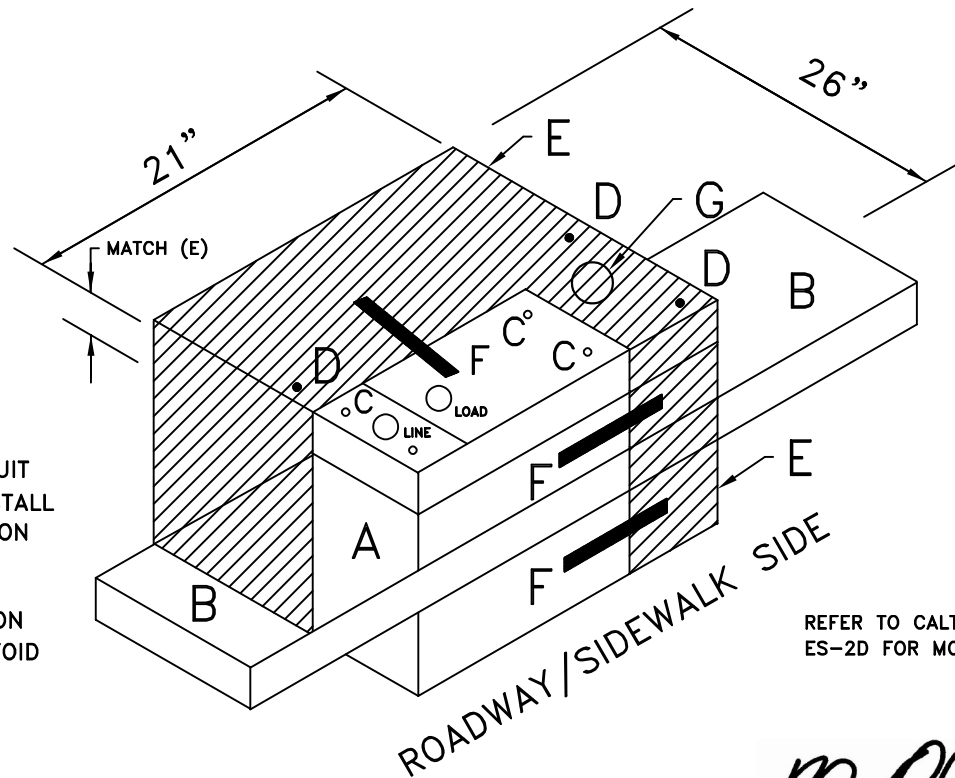

REFER TO CALTRANS STANDARD PLANS ES-2D FOR MORE CABINET INFORMATION

RHON HERNDON  
PUBLIC WORKS DIRECTOR

CITY OF  
**ROSEVILLE**  
CALIFORNIA

DEPARTMENT OF  
PUBLIC WORKS

EXISTING TYPE III-AF 27-22 COMBO  
PAD CONVERSION DETAIL

SCALE: NONE  
REVISED: JANUARY 1, 2025  
DRAWN BY: J MCKINNEY  
APPROVED BY: RHON HERNDON

TS-8

**LEGEND**

A= TYPE "A" OR "E" LOOP  
 D= TYPE "D" LOOP OR QUADRACIRCLE  
 1-1= LANE # , LOOP#  
 COUNT= COUNT LOOP

\* ALL LOOPS WOUND CLOCKWISE  
 \* CENTER LOOPS IN EFFECTIVE AREA.  
 \* HANDHOLES SHALL BE PLACED BETWEEN PRESENCE & COUNT LOOPS IN THE THROUGH LANES.

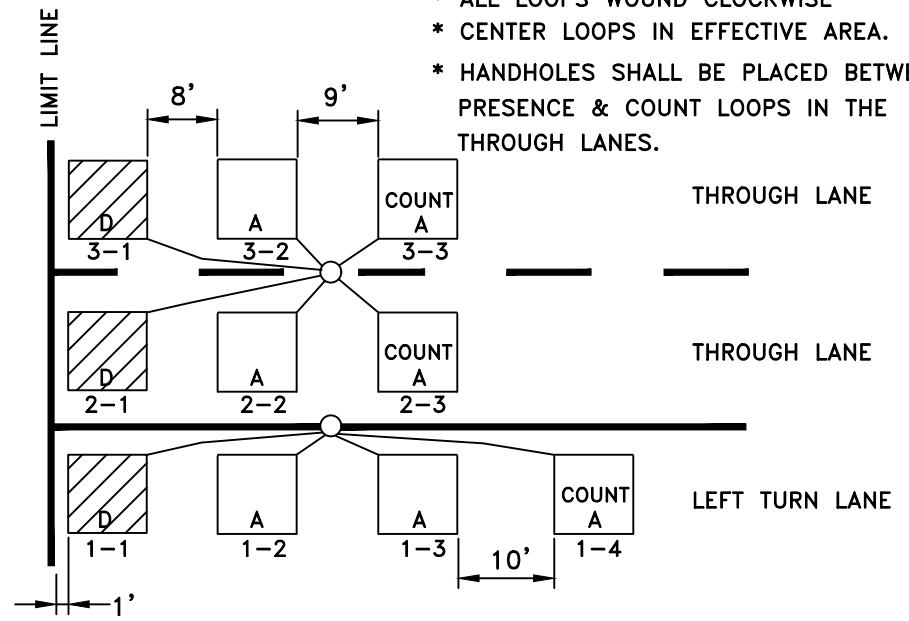

**332 LOOP DETECTOR ASSIGNMENTS**

	(1) LT		(2) LT		(1) THRU		(2) THRU		(3) THRU	
	170	2070	170	2070	170	2070	170	2070	170	2070
CALL TYPE 3/QUEUE ⊙	111U 315U 5J1U 7J5U	1 7 15 21	111L 315L 5J1L 7J5L	1 7 15 21	214U 418U 6J4U 8J8U	6 12 20 26	214L 418L 6J4L 8J8L	6 12 20 26		
COUNT/VOLUME TYPE 3/QUEUE #		119U 319L 5J9U 7J9L	13 14 27 28	213U 417U 6J3U 8J7U	4 10 18 24	212U 416U 6J2U 8J6U	2 8 16 22	212L 416L 6J2L 8J6L	3 9 17 23	
EXTENSION					213L 417L 6J3L 8J7L	5 11 19 25				

⊙ = L/T's are Call/Extension Detectors  
 # = L/T's are Count-Volume/Extension Detectors

\* Separate DLC's shall be provided for each loop detector and a permanent label shall be provided to designate their location.

RHON HERNDON  
 PUBLIC WORKS DIRECTOR

	DEPARTMENT OF PUBLIC WORKS
	332 TYPICAL LOOP DETECTOR LAYOUT
SCALE: NONE REVISED: JANUARY 01, 2018 DRAWN BY: J PASTOR APPROVED BY: RHON HERNDON	TS-9

# TYPE "P" CABINET DETECTOR LAYOUT

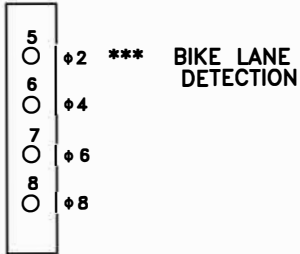
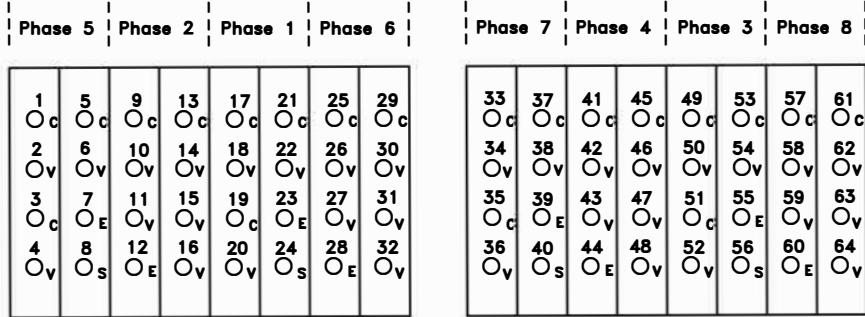

A = TYPE "A" OR "E" LOOP  
D = TYPE "D" OR QUADRACIRCLE

# 2070 LOOP DETECTOR ASSIGNMENTS

	(1) L	(2) L	(3) L	(1) THRU	(2) THRU	(3) THRU	(4) THRU	(5) R/T
<b>CALL QUEUE</b> C	1/17 3/49 5/1 7/33	1/19 3/51 5/3 7/35	1/21 3/53 5/5 7/37	2/9 4/41 6/25 8/57		2/13 4/45 6/29 8/61		
<b>VOLUME QUEUE</b> V	1/18 3/50 5/2 7/34	1/20 3/52 5/4 7/36	1/22 3/54 5/6 7/38	2/10 4/42 6/26 8/58	2/11 4/43 6/27 8/59	2/14 4/46 6/30 8/62	2/15 4/47 6/31 8/63	2/16 4/48 6/32 8/64
<b>EXTENSION</b> E		1/23 3/55 5/7 7/39			2/12 4/44 6/28 8/60			

⊙ = L/T's are Call/Extension Detectors  
# = L/T's are Volume/Extension Detectors  
\*\*\* = If Phase 5 is a Tripple L/T use the Phase 1 Second Slot for Bike Lane Detection

RHON HERNDON  
PUBLIC WORKS DIRECTOR

## TYPICAL LEFT TURNS

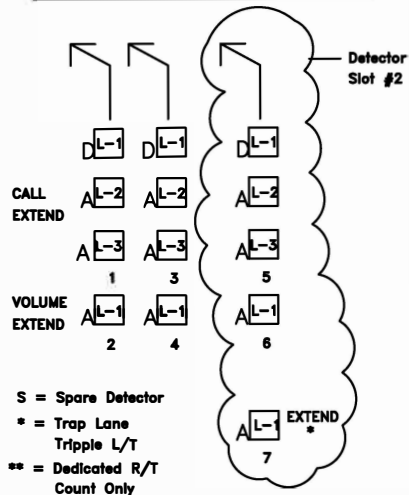

S = Spare Detector  
\* = Trap Lane Tripple L/T  
\*\* = Dedicated R/T Count Only

## TYPICAL THRU LANES

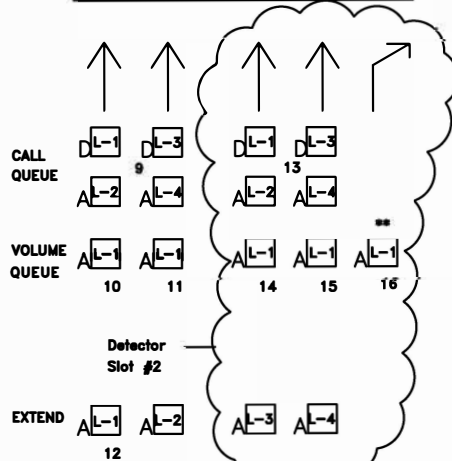

NOTE: - Separate DLC's shall be provided for each loop detector and a name label shall be provided to designate their location.

perma - All loops shall be wound clockwise



DEPARTMENT OF  
PUBLIC WORKS

## TYPE P CABINET LOOP DETECTOR LAYOUT

SCALE: NONE  
REVISED: OCTOBER 26, 2017  
DRAWN BY: J PASTOR  
APPROVED BY: RHON HERNDON

TS-10

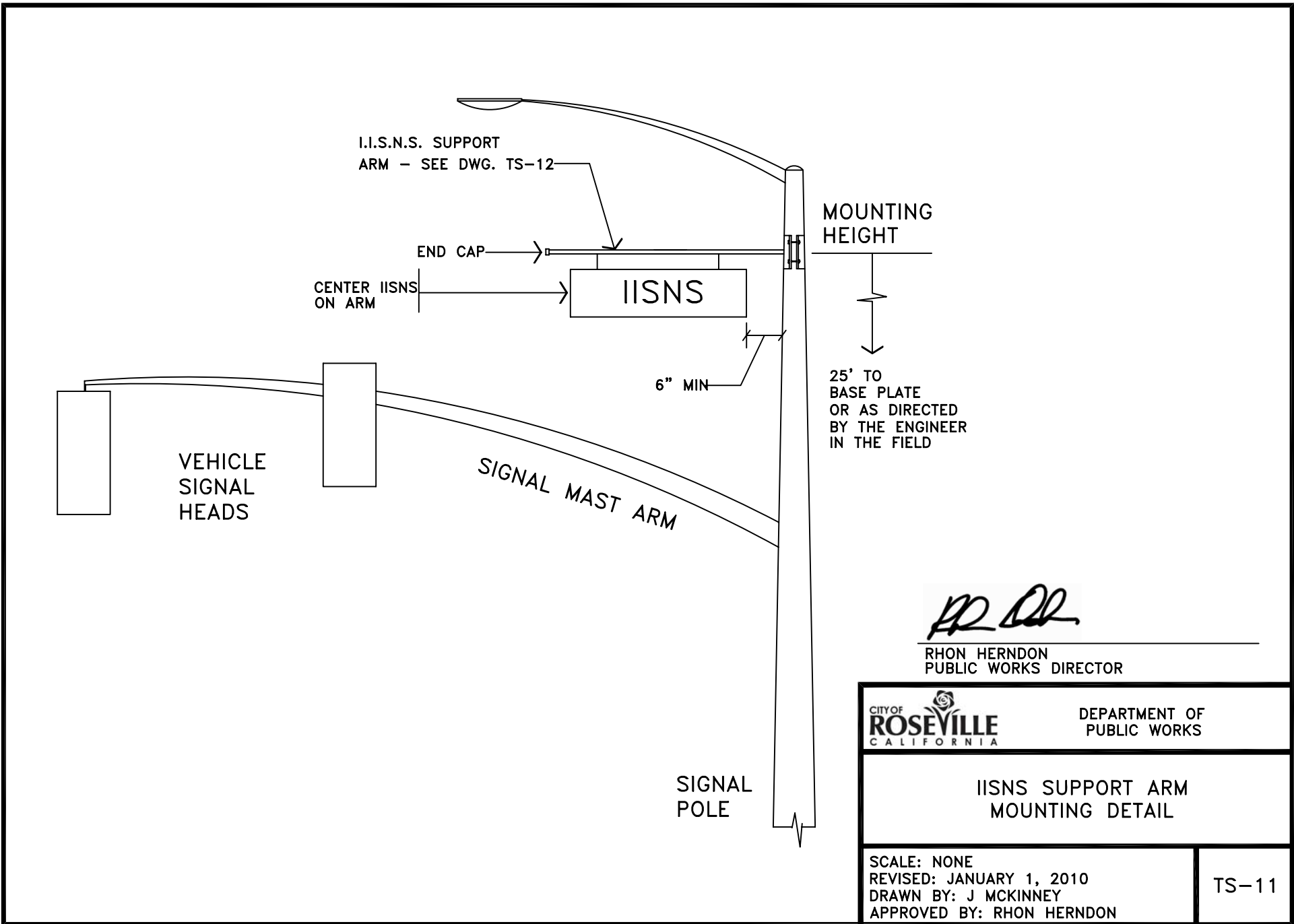

*RH Herndon*

RHON HERNDON  
PUBLIC WORKS DIRECTOR

CITY OF **ROSEVILLE** CALIFORNIA  
DEPARTMENT OF PUBLIC WORKS

IISNS SUPPORT ARM  
MOUNTING DETAIL

SCALE: NONE  
REVISED: JANUARY 1, 2010  
DRAWN BY: J MCKINNEY  
APPROVED BY: RHON HERNDON

TS-11

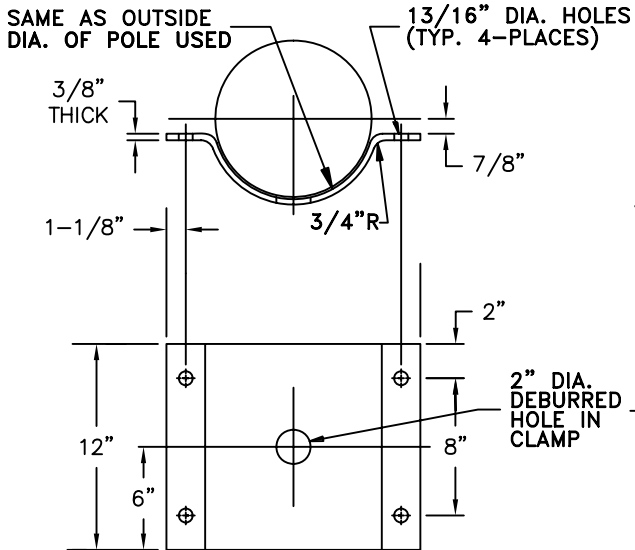
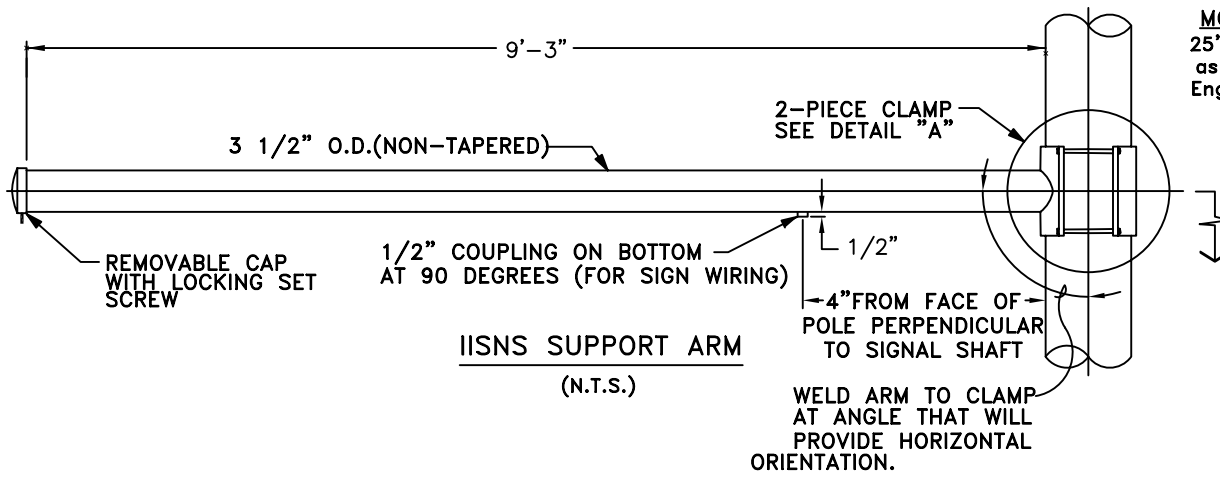

**CLAMP DETAILS**  
(N.T.S.)

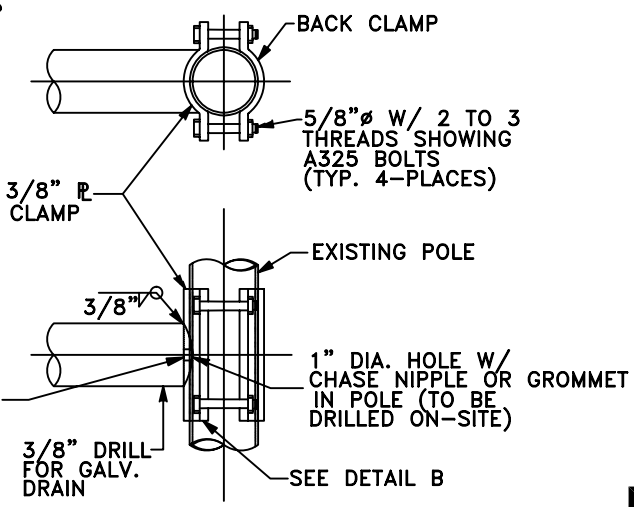

**DETAIL A**

GENERAL NOTES	
MATERIAL SPECIFICATIONS	
SHAFT	STEEL OF 48,000 PSI MINIMUM YIELD AFTER FABRICATION
CLAMP PLATE	ASTM A-572 GR. 50 STEEL
MANUFACTURING PROCESSES	
LONGITUDINAL WELDS	ALL WELDS SHALL CONFORM TO AWS D1.1 WELD SPECIFICATION
FINISH COATING	
STRUCTURE	HOT DIP GALVANIZED PER ASTM A-123
HARDWARE	HOT DIP GALVANIZED PER ASTM A-153
DESIGN CRITERIA	
STRUCTURE, HARDWARE, AND WELDING	IN ACCORDANCE WITH THE "SPECIFICATIONS FOR STRUCTURAL SUPPORTS OF HIGHWAY SIGNS, LUMINAIRES AND TRAFFIC SIGNALS", AASHTO 1994

A SEPARATE LIGHTING CIRCUIT SHALL BE INSTALLED TO POWER THE SIGNS. (120 V./TWO #12 AWG CONDUCTORS). A 3/4" LB CONDUIT SHALL BE INSTALLED AS A DISCONNECTING POINT BETWEEN THE SIGN AND THE SYSTEM POWER SOURCE.

RHON HERNDON  
PUBLIC WORKS DIRECTOR

CITY OF **ROSEVILLE** CALIFORNIA

DEPARTMENT OF PUBLIC WORKS

**IISNS SUPPORT ARM  
TYPICAL CLAMP DETAIL**

NOTE: FURNISH SEPARATE CIRCUIT FOR IISNS TO BE CONNECTED TO THE BATTERY BACKUP

*INCLUDE ENGINEERED SUPPORT ARM AND SIGNAL POLE LOAD CALCULATIONS IF NOT ALREADY ON FILE WITH THE CITY.*

SCALE: NONE  
REVISED: JANUARY 1, 2010  
DRAWN BY: J MCKINNEY  
APPROVED BY: RHON HERNDON

TS-12

**LEGEND:**

1. SURFACE OF EXISTING STREET SECTION.
2. .25' THICK PAVEMENT PER SECTION 71-4.D. (93% RELATIVE COMPACTION).
3. PIPE COVER TO BE A MINIMUM 18" (18" MIN TO 30" MAX).
4. DISTANCE VARIES. IF LESS THAN 3 FEET, THEN CONTRACTOR IS REQUIRED TO EDGE GRIND FROM LIP OF GUTTER (.15' DEEP) TO INSIDE LIMIT LINE OF TRENCH.
5. EXISTING CURB AND GUTTER.
6. "MINOR CONCRETE" CONFORMING TO THE PROVISIONS IN SECTION 71-5B, "CONCRETE", WITH FINE AGGREGATE (PEA GRAVEL MIX). CONCRETE SHALL BE FLOW-ABLE AT DISCRETION OF CITY INSPECTOR.
7. CONDUIT(S) AS SPECIFIED.
8. CENTER LINE OF BIKE LANE STRIPE.
9. PLACE BINDER (TACK COAT) ON ALL SURFACES PRIOR TO PAVING PER SECTION 39 OF STATE STANDARD SPECIFICATIONS, OR SAWCUT CONCRETE PER STREETS DETAIL ST-54
10. REINFORCING BARS 2 - #3 TO SUPPORT MULTIPLE CONDUITS, VERTICAL ALIGNMENT ONLY. REINFORCING BARS SHALL BE DRIVEN 6" INTO BOTTOM OF TRENCH AND WIRED TOGETHER AT THE TOP. REINFORCING BAR SUPPORTS SHALL BE 8'-0" ON CENTER. MAXIMUM 3 - 3" CONDUITS PER ROCKWHEEL TRENCH.

**NOTES:**

1. THE CONTRACTOR IS RESPONSIBLE FOR REPLACEMENT OF BIKE LANE STRIPE AND LEGENDS (AFFECTED BY TRENCHING) WITH THERMOPLASTIC MATERIAL.
2. ALL EXCAVATED AREAS IN THE PAVEMENT SHALL BE BACKFILLED, EXCEPT FOR THE TOP 0.25' BY THE END OF EACH WORK DAY. THE TOP .25' SHALL BE PLACED WITHIN 3 WORKING DAYS AFTER TRENCHING. DELINEATORS SHALL BE PLACED ON TEN FOOT CENTERS, AND WITHIN 1' OF EACH SIDE OF DRIVEWAYS IN THE INTERIM. REFER TO SECTION 6.2.W.5. FOR TRANSITION LOCATIONS.
3. TRENCH CUT FEE SHALL APPLY PER CITY ORDINANCE. NO ALTERNATE TRENCH CONFIGURATION IS ALLOWED.
4. DETECTOR HANDHOLES (DH's) CONDUIT SHALL BE INSTALLED IN A SEPARATE TRENCH.

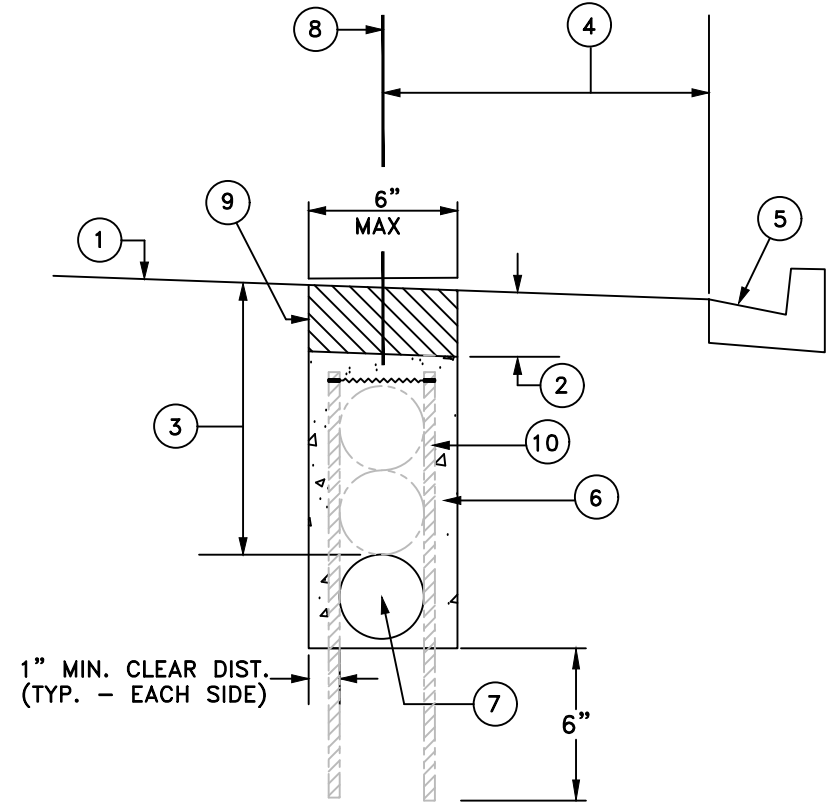

JASON SHYKOWSKI  
PUBLIC WORKS DIRECTOR



DEPARTMENT OF  
PUBLIC WORKS

TRAFFIC SIGNAL ROCK WHEEL TRENCH  
(IN EXISTING A.C. STREETS)

SCALE: NONE  
REVISED: FEBRUARY 2021  
DRAWN BY: J PASTOR  
APPROVED BY: JASON SHYKOWSKI

TS-13

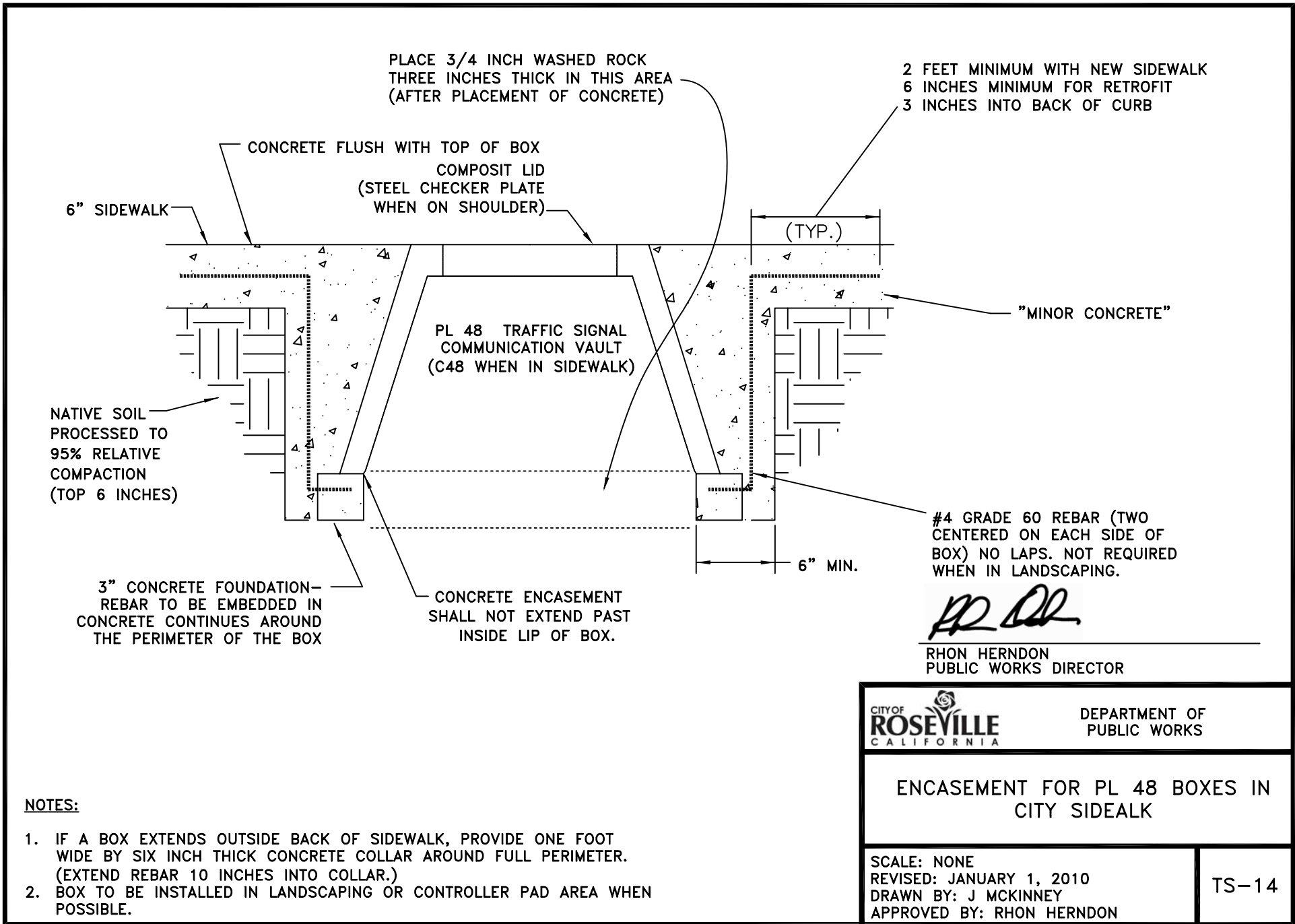

PLACE 3/4 INCH WASHED ROCK  
THREE INCHES THICK IN THIS AREA  
(AFTER PLACEMENT OF CONCRETE)

2 FEET MINIMUM WITH NEW SIDEWALK  
6 INCHES MINIMUM FOR RETROFIT  
3 INCHES INTO BACK OF CURB

CONCRETE FLUSH WITH TOP OF BOX  
COMPOSIT LID  
(STEEL CHECKER PLATE  
WHEN ON SHOULDER)

6" SIDEWALK

(TYP.)

PL 48 TRAFFIC SIGNAL  
COMMUNICATION VAULT  
(C48 WHEN IN SIDEWALK)

"MINOR CONCRETE"

NATIVE SOIL  
PROCESSED TO  
95% RELATIVE  
COMPACTION  
(TOP 6 INCHES)

#4 GRADE 60 REBAR (TWO  
CENTERED ON EACH SIDE OF  
BOX) NO LAPS. NOT REQUIRED  
WHEN IN LANDSCAPING.

3" CONCRETE FOUNDATION—  
REBAR TO BE EMBEDDED IN  
CONCRETE CONTIGUES AROUND  
THE PERIMETER OF THE BOX

CONCRETE ENCASEMENT  
SHALL NOT EXTEND PAST  
INSIDE LIP OF BOX.

6" MIN.

*RH Herndon*

RHON HERNDON  
PUBLIC WORKS DIRECTOR

 CITY OF <b>ROSEVILLE</b> CALIFORNIA	DEPARTMENT OF PUBLIC WORKS
--	-------------------------------

**ENCASEMENT FOR PL 48 BOXES IN  
CITY SIDEWALK**

**NOTES:**

1. IF A BOX EXTENDS OUTSIDE BACK OF SIDEWALK, PROVIDE ONE FOOT WIDE BY SIX INCH THICK CONCRETE COLLAR AROUND FULL PERIMETER. (EXTEND REBAR 10 INCHES INTO COLLAR.)
2. BOX TO BE INSTALLED IN LANDSCAPING OR CONTROLLER PAD AREA WHEN POSSIBLE.

SCALE: NONE  
 REVISED: JANUARY 1, 2010  
 DRAWN BY: J MCKINNEY  
 APPROVED BY: RHON HERNDON

TS-14

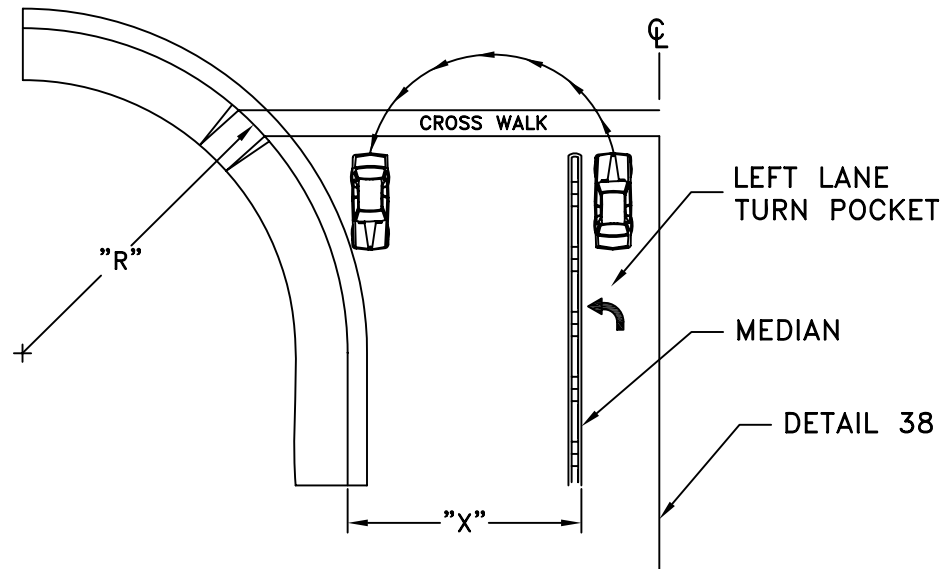

*RHON HERNDON*

RHON HERNDON  
PUBLIC WORKS DIRECTOR

**NOTES:**

1. U-TURNS ARE PERMISSIBLE UNDER THE FOLLOWING CONDITIONS:  
IF "R" < 50', THEN "X" ≥ 35'  
IF "R" ≥ 50', THEN "X" ≥ 30'
2. U-TURNS MAY BE RESTRICTED DUE TO RIGHT TURN OVERLAPS OR OTHER CONDITIONS DETERMINED BY THE CITY ENGINEER.
3. SIGN DETAILS NUMBERS REFERENCE THE 2006 CALIFORNIA MUTCD.
4. INSTALL TYPE R73-5 SIGN WHERE DUAL LEFT TURNS AND U-TURNS ARE PERMITTED.
5. WHERE U-TURNS ARE PERMITTED FOR A SINGLE LEFT TURN, NO SIGNS ARE NECESSARY.

	DEPARTMENT OF PUBLIC WORKS
<h2>U-TURNS</h2>	
SCALE: NONE REVISED: JANUARY 1, 2013 DRAWN BY: J MCKINNEY APPROVED BY: RHON HERNDON	
TS-15	

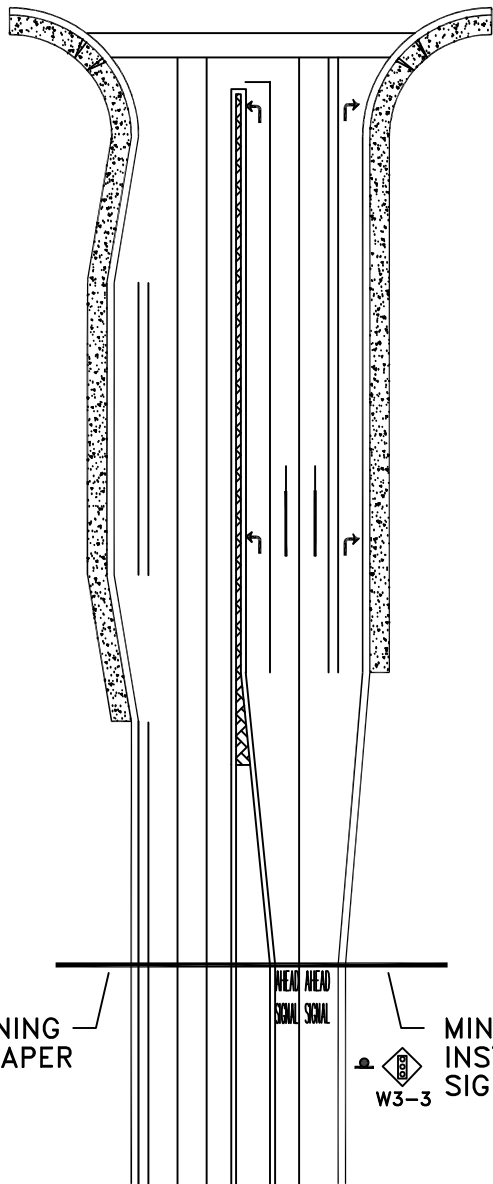

POSTED OR 85TH PERCENTILE SPEED	ADVANCED STREET G7 SIGNS	ADVANCED W3-1, W3-3, SIGNS	NO PARKING SIGNS
20MPH	175FT	N/A	300FT
25MPH	250FT	N/A	300FT
30MPH	325FT	100FT	300FT
35MPH	400FT	150FT	300FT
40MPH	475FT	225FT	300FT
45MPH	550FT	300FT	300FT
50MPH	625FT	375FT	300FT
55MPH	700FT	450FT	300FT
60MPH	775FT	550FT	300FT
65MPH	850FT	650FT	300FT

\* USE EXISTING STREET LIGHT POLES WHERE POSSIBLE

RHON HERNDON  
PUBLIC WORKS DIRECTOR



DEPARTMENT OF  
PUBLIC WORKS

ADVANCED SIGN  
SPACING REQUIREMENTS

SCALE: NONE  
REVISED: NOVEMBER 22, 2019  
DRAWN BY: J PASTOR  
APPROVED BY: J CERVANTES

TS-16

**LEGEND:**

1. STREET NAME SIGNS.
2. SIGN POST SHALL BE SQUARE METAL WHITE POWDER COATED 12 GAUGE POSTS. REFER TO SECTION 56.02A.
3. EDGE OF STREET NAME SIGN SHALL BE A MINIMUM OF 2' FROM FACE OF CURB OR AT BACK OF SIDEWALK.
4. POST HOLE FOOTING SHALL BE 24" DEEP AND  $\phi 6"$  IN DIAMETER AND BACKFILLED WITH MINOR CONCRETE.
5. 24" GALVANIZED ANCHOR SLEEVE SHALL BE INSTALLED IN POST FOOTING. TOP TWO HOLES OF ANCHOR SLEEVE SHALL REMAIN ABOVE FINISH GRADE OF CONCRETE, HOLES BELOW FISH GRADE SHALL BE TAPED CLOSED. NO MATERIAL OTHER THAN SQUARE POST SHALL INTRUDE INTO SLEEVE. THE SQUARE POST SHALL MOVE FREELY IN THE SLEEVE IN A VERTICAL DIRECTION UPON INSTALLATION.
6. SIGN PLATE ATTACHMENT SHALL USE  $\frac{5}{16}" \times 2\frac{1}{2}"$  ZINC PLATED HEX HEAD BOLTS AND NUTS.  $\frac{5}{16}"$  ZINC PLATED WASHERS SHALL BE USED INSIDE OF BOLT AND NUT PER TOP VIEW DETAIL BELOW.

**SIGN PLATE SPECIFICATIONS:**

- A. SIGN PLATES SHALL BE 8" OR 12" TALL AND 24" TO 48" LONG IN 6" INCREMENTS.
- B. SIGN PLATES SHALL BE 0.080 GAUGE ALUMINUM.
- C. SIGN PLATE FINISH SHALL BE 3M HIGH INTENSITY PRISMATIC GRADE RETRO REFLECTIVE BACKGROUND WITH 3M ELECTRONIC CUTTABLE GREEN FILM SHEETING OR APPROVED EQUIVALENT.
- D. FONT FOR STREET NAME SIGNS SHALL BE FHWA SERIES "D" 2000EX. IF STREET NAME TEXT IS TOO LONG FOR 48" SIGN PLATE, SERIES "C" FHwy FONT MAY BE USED UPON APPROVAL FROM PUBLIC WORKS DIRECTOR.

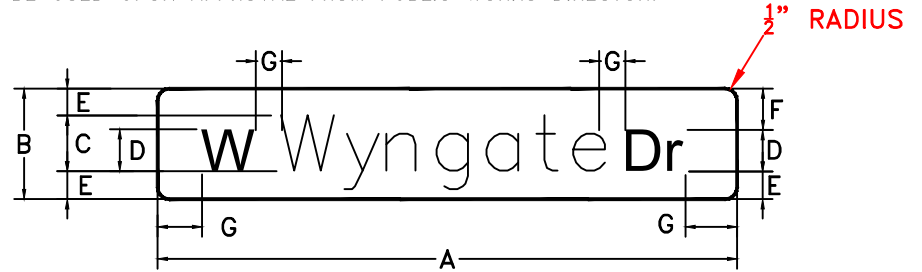

SIGN DIMENSIONS							
MPH	A	B	C	D	E	F	G
25	VARIABLE	8"	4"	3"	2"	3"	3"
≥30	VARIABLE	12"	6"	4"	3"	5"	4.5"

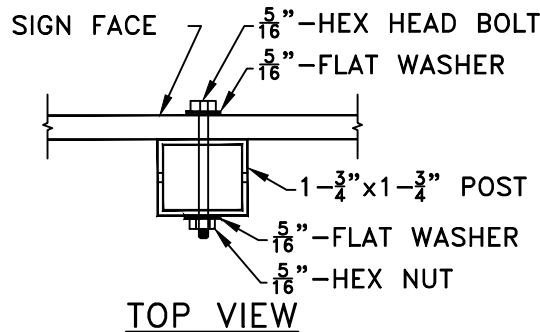
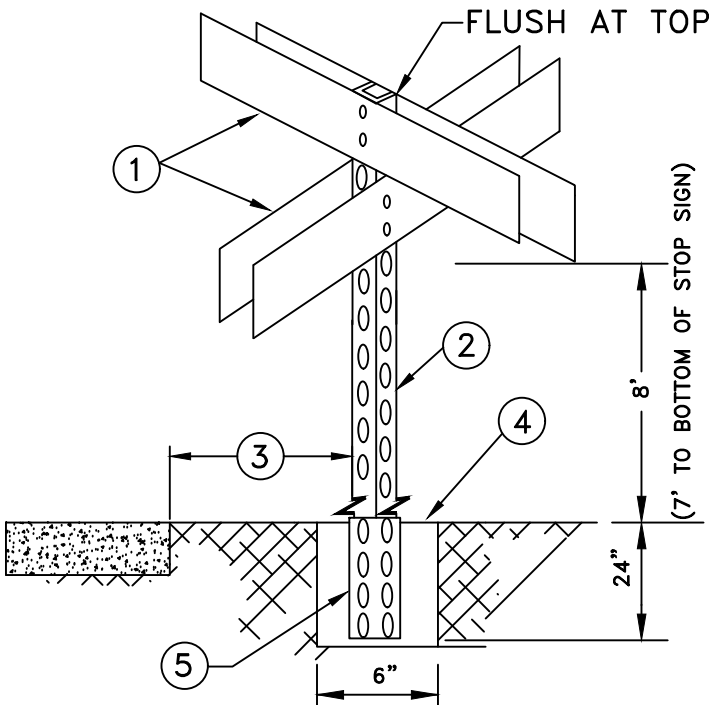

MARC STOUT  
CITY ENGINEER

CITY OF  
**ROSEVILLE**  
CALIFORNIA

DEVELOPMENT SERVICES  
DEPARTMENT

ROADWAY SIGNS

SCALE: NONE  
REVISED: **JANUARY 2025**  
DRAWN BY: **J PASTOR**  
APPROVED BY: **J CERVANTES**

TS-17A

**LEGEND:**

1. STREET NAME SIGNS, D3 OR G8 GUIDE SIGN.
2. SIGN POST SHALL BE SQUARE METAL WHITE POWDER COATED 12 GAUGE POSTS. REFER TO SECTION 56.02A.
3. EDGE OF STREET NAME SIGN SHALL BE A MINIMUM OF 2' FROM FACE OF CURB OR AT BACK OF SIDEWALK.
4. POST HOLE FOOTING SHALL BE 24" DEEP AND  $\phi 6"$  IN DIAMETER AND BACKFILLED WITH MINOR CONCRETE.
5. 24" GALVANIZED ANCHOR SLEEVE SHALL BE INSTALLED IN POST FOOTING. TOP TWO HOLES OF ANCHOR SLEEVE SHALL REMAIN ABOVE FINISH GRADE OF CONCRETE, HOLES BELOW FISH GRADE SHALL BE TAPED CLOSED. NO MATERIAL OTHER THAN SQUARE POST SHALL INTRUDE INTO SLEEVE. THE SQUARE POST SHALL MOVE FREELY IN THE SLEEVE IN A VERTICAL DIRECTION UPON INSTALLATION.
6. THE SIGN MUST BE FASTENED TO THE BACK BRACING USING NO.14  $\times \frac{3}{4}"$  LONG SELF TAPPING SCREWS, RIVETS OR APPROVED EQUAL AND SPACED 10" OFF CENTER.
7. BACK BRACING FOR SIGNS OVER FIVE SQUARE FEET SHALL BE CONNECTED TO THE POST. THE BACK BRACING SHALL BE MINIMUM OF  $1-\frac{5}{8}" \times 1\frac{3}{8}" \times L$  (LENGTH VARIES), 14 GAUGE MINIMUM. A USTRUT, U-CHANNEL, SQUARE TUBING, C-CHANNEL OR APPROVED EQUAL CAN BE USED.
8. SIGN PLATE AND BACK BRACING ATTACHMENT SHALL USE  $\frac{5}{8}"-18 \times 3-\frac{1}{2}"$  ZINC PLATED HEX HEAD BOLTS WITH  $\frac{5}{8}"$  ZINC PLATED HEX NUTS USING  $\frac{5}{16}"$  WASHER BETWEEN BOLT/HEAD AND SIGN PLATE. THREADS SHALL NOT PROTRUDE FARTHER THEN  $\frac{1}{4}"$  PAST THE HEX NUT.

**SIGN PLATE SPECIFICATIONS:**

- A. TEXT SIZE SHALL BE 8" UPPER AND LOWER CASE WHITE HIGH INTENSITY PRISMATIC (HIP) OR APPROVED EQUAL. SERIES C HIGHWAY FONT TEXT WILL BE CENTERED TOP AND BOTTOM AND SIDES HAVE A MINIMUM 5.33" CLEAR SPACE FROM EDGE OF SIGN PLATE. IN THE EVENT A 8" HIGHWAY FONT EXCEEDS 96", 7" SERIES "C" HIGHWAY FONT MAY BE USED, AT THE DISCRETION OF THE PUBLIC WORKS DIRECTOR
- B. SIGN PLATES SHALL BE 0.080 GAUGE ALUMINUM.
- C. SIGN PLATE FINISH SHALL BE 3M HIGH INTENSITY PRISMATIC GRADE RETRO REFLECTIVE BACKGROUND WITH 3M ELECTRONIC CUTTABLE GREEN FILM SHEETING OR APPROVED EQUIVALENT. LETTER OF AUTHENTICITY IS REQUIRED. SEE CONSTRUCTION STANDARDS SEC 56 - SIGNS, 56 - 1.01.
- D. SIGNS SHALL BE D3 OR G8 GUIDE SIGNS.

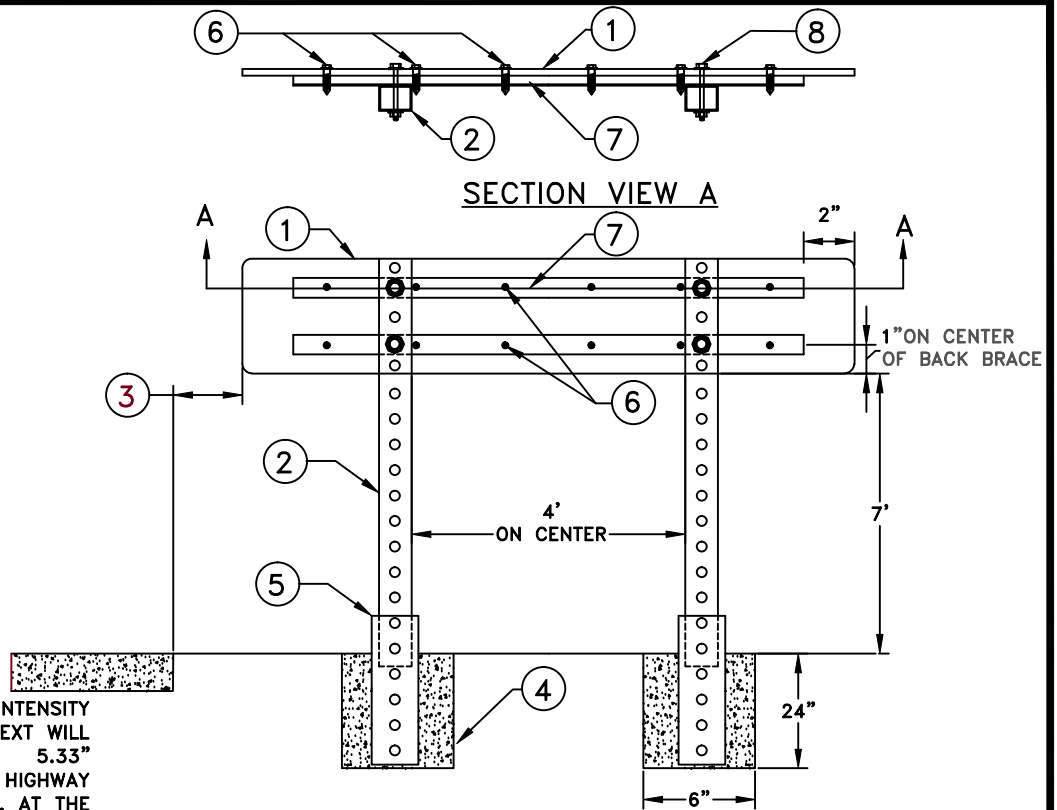

*Marc Stout*

MARC STOUT  
CITY ENGINEER

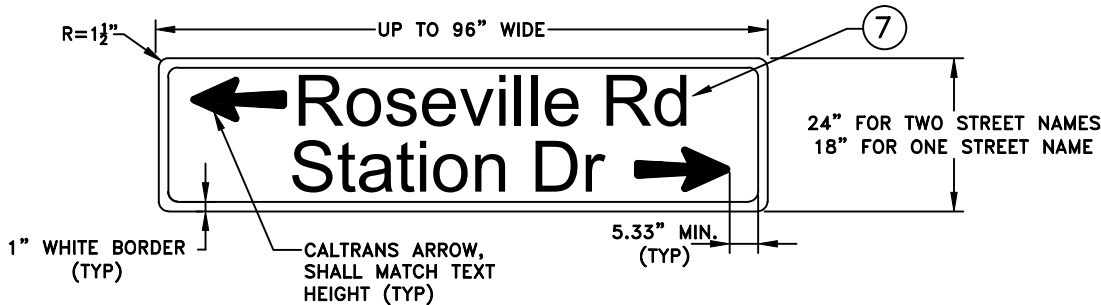

	DEVELOPMENT SERVICES DEPARTMENT
<h2 style="margin: 0;">MID BLOCK ROADWAY SIGNS</h2>	
SCALE: NONE REVISED: JANUARY 1, 2016 DRAWN BY: J HENDRIX APPROVED BY: MARC STOUT	TS-17B

# SIGNALIZED INTERSECTIONS

Extend bike lane (Detail 39) to the signalized intersection.

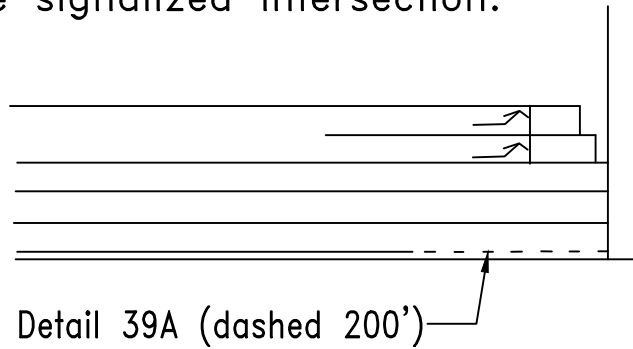

# PUBLIC ROADWAYS

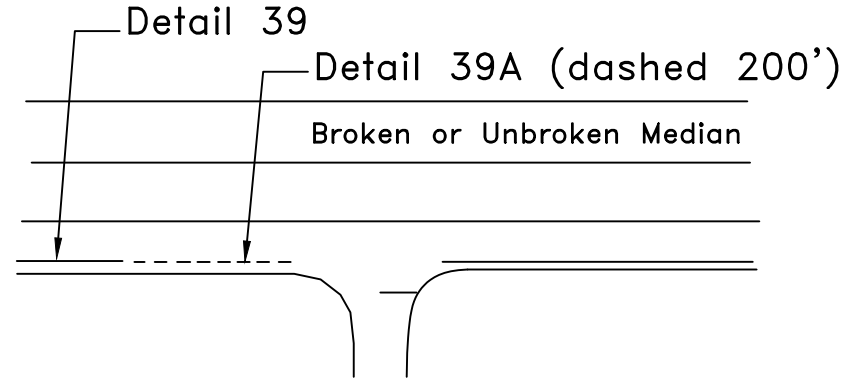

# PRIVATE DRIVEWAYS WITH A LEFT-TURN LANE

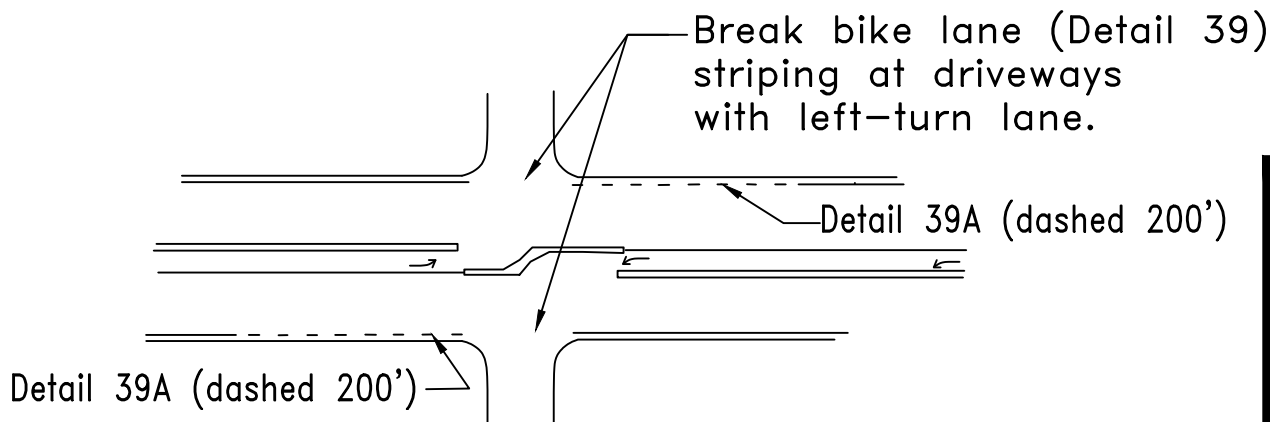

*RHON HERNDON*

RHON HERNDON  
PUBLIC WORKS DIRECTOR

CITY OF  
**ROSEVILLE**  
CALIFORNIA

DEPARTMENT OF  
PUBLIC WORKS

BIKE LANE STRIPING A

SCALE: NONE  
REVISED: JANUARY 01, 2018  
DRAWN BY: J PASTOR  
APPROVED BY: J CERVANTES

TS-18

## AUXILLARY LANES

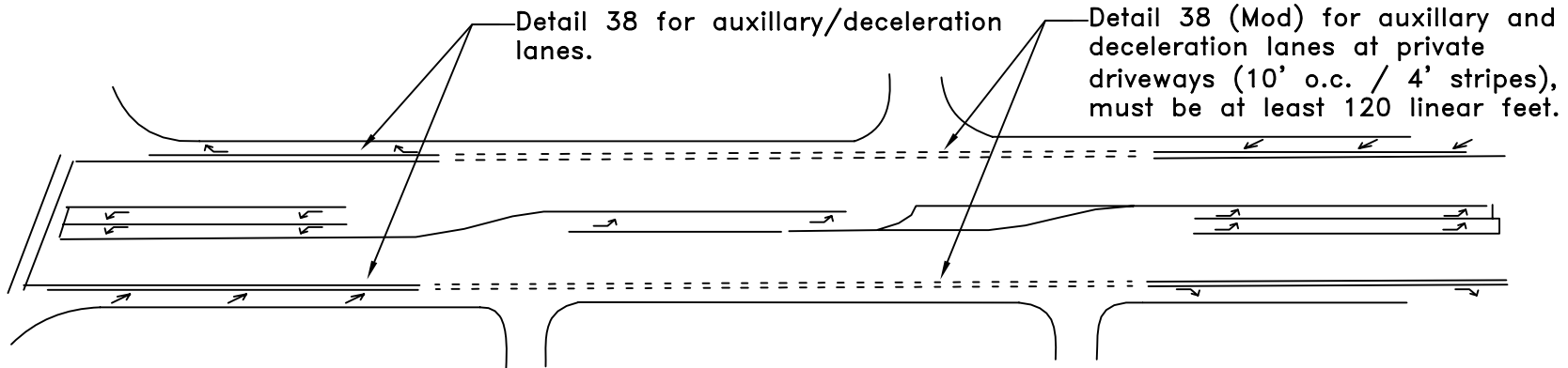

## PRIVATE DRIVEWAYS WITHOUT A LEFT-TURN LANE

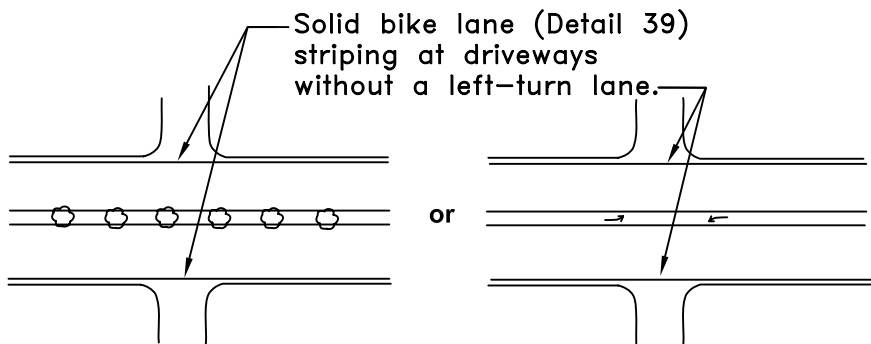

*RHON HERNDON*

RHON HERNDON  
PUBLIC WORKS DIRECTOR

CITY OF  
**ROSEVILLE**  
CALIFORNIA

DEPARTMENT OF  
PUBLIC WORKS

BIKE LANE STRIPING

SCALE: NONE  
REVISED: JANUARY 1, 2010  
DRAWN BY: J MCKINNEY  
APPROVED BY: RHON HERNDON

TS-19

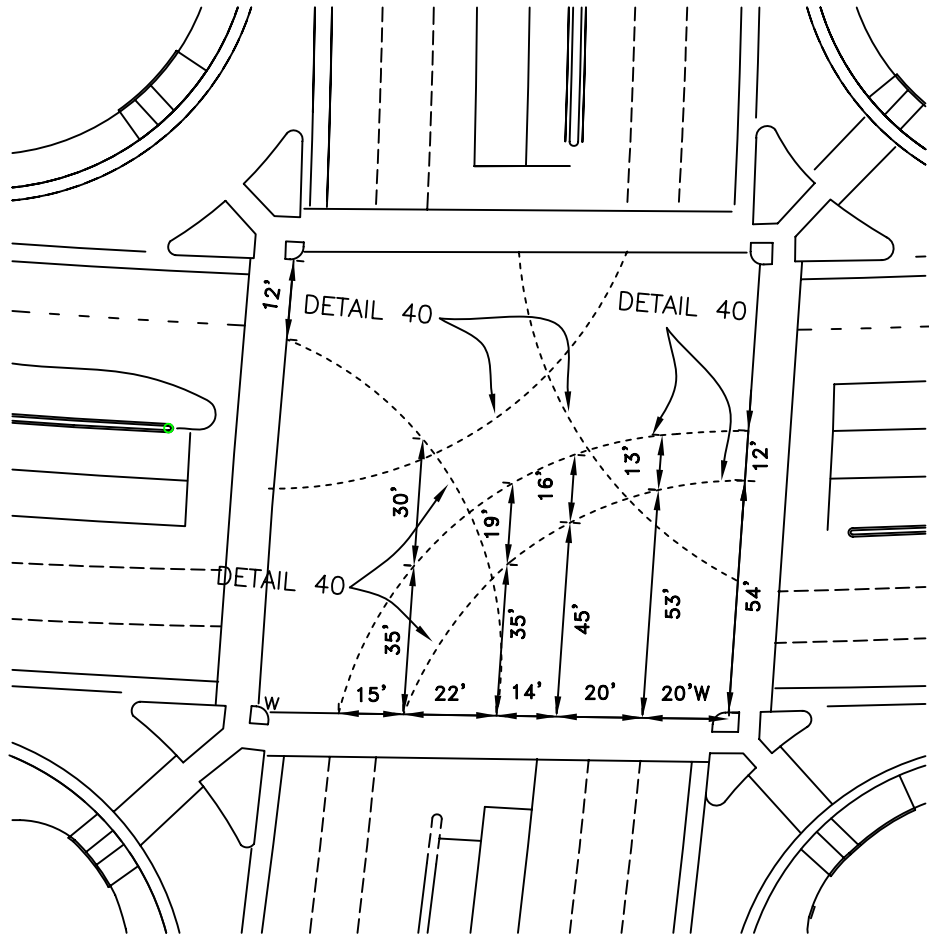

*RHON HERNDON*

RHON HERNDON  
PUBLIC WORKS DIRECTOR



DEPARTMENT OF  
PUBLIC WORKS

TRIPLE LEFT STRIPING

SCALE: NONE  
REVISED: JANUARY 1, 2010  
DRAWN BY: J MCKINNEY  
APPROVED BY: RHON HERNDON

TS-20



INTERSECTION RED FLASH APPROVAL

With stamped approval of this letter by the Traffic Section, Red Flash/Dark Signal is approved for the following intersection as specified below:

LOCATION: \_\_\_\_\_

PROJECT ACCOUNT NUMBER: \_\_\_\_\_

DATE: \_\_\_\_\_

TIME/DURATION: \_\_\_\_\_

RED FLASH APPROVED:

- 1. Contractor shall submit the completed Intersection Red Flash Approval Form to the City Inspector and to TRedFlashRequests@roseville.ca.us 72 hours prior to needing the intersection in red flash. Signal shutdown shall be performed only by City personnel, unless otherwise directed by the Engineer.
2. During normal working hours (M-F, 7am-5pm) the contractor shall contact the Traffic Signal Technician either by telephone at (916) 746-1760 or by email or text message at pagesignaltechnicians@roseville.ca.us one hour prior to needing the traffic signal placed into or removed from red flash. Outside of normal working hours - no phone call required.
3. The traffic signal will not be permitted to be placed in red flash during rain, lightning, or inclement weather conditions (including wet pavement conditions).
4. The Contractor shall reimburse the City for the actual cost of all inspection, including City Traffic Signal Technician time as required.
5. "Road Work Ahead" Signs required at all approaches to intersection when in red flash.
6. The Contractor shall furnish and place 36" "Stop" signs on arterial roadway approaches. Signs shall be mounted at a height of 84".

DARK SIGNAL APPROVED - ADDITIONAL REQUIREMENTS

- 1. The Contractor shall place "Stop Ahead" C-W17 and "Stop" R-1 signs to direct vehicle and pedestrian traffic through the intersection during traffic signal system shutdown. Temporary "Stop Ahead" and "Stop" signs shall be removed when the system is turned on.
2. "Stop Ahead" and "Stop" signs shall be furnished by the Contractor. Minimum size of "Stop" signs shall be 36" for single sign placements and 24" for dual sign placements. Signs shall be mounted at a height of 84".
3. One "Stop Ahead" sign and one "Stop" sign shall be placed for each direction of traffic. For approaches with two or more through or left turn lanes, two "Stop" signs shall be placed. Typical sign placement should be between the left turn and through lanes. Additional "Stop" signs should be placed on the shoulder. No "Stop" signs shall be placed in a manner that blocks bike lanes.
4. "Stop Ahead" and "Stop" signs shall be in place in each direction immediately prior to the intersection going dark and removed immediately after the intersection is placed back into red flash.
5. Red flashing beacons or flares shall be placed and maintained at each "Stop" sign during nighttime (dark) hours.
6. Traffic control must be verified by the Public Works Construction Inspector prior to the signal being deactivated.

I have read the above Intersection Red Flash Approval requirements.

REQUESTOR INFO: Name of Company \_\_\_\_\_

Print Name of Requestor \_\_\_\_\_ Contact Phone Number \_\_\_\_\_

SIGNATURE: X \_\_\_\_\_ / / Date

INSPECTOR NAME: \_\_\_\_\_ Inspector. Phone #: \_\_\_\_\_

Copy To: Contractor, Public Works Inspector, Signal Technicians, NOTE: Contractor is required to follow all requirements of this letter and keep a signed and stamped copy at job site.

# Traffic Signal Inspection Check List

DSI – Development Services Inspector

TECH – Signal Technician

ENG – City Traffic Engineer

ATMS – Advanced Traffic Management System

## PRIOR TO BEGINNING WORK

- Pre-Job** – DSI - DSI to e-mail the Signal Technicians a minimum of 24 hours prior to the scheduled project pre-job meeting. The TECH assigned to the project will respond to the DSI's e-mail confirming attendance.
- Communications** – DSI - At the pre-job meeting, the chain of communication shall be clearly defined. Requests for inspection, City supplied equipment, beginning of functional testing, and the scheduling of signal turn-on must be through the DSI. All other communication should either go through or be relayed to the DSI.

## DURING CONSTRUCTION

- Approve Pole Locations** – DSI, TECH, ENG – Pole locations, face of curb, utilities, limit lines, and lane lines shall be clearly marked and checked by the DSI prior to requesting inspection by the TECH and ENG.
- Approve Controller and Service Cabinet Locations** – DSI, TECH, ENG – Face of curb, back of walk, and signal poles shall be clearly marked and verified by the DSI prior to requesting inspection by the TECH and ENG
- Approve PTZ Camera Location** – DSI, TECH, ENG
- Approve Loop/Handhole Layout** – DSI, TECH, ENG – Lane lines, limit lines, and medians shall be clearly marked and verified by the DSI prior to inspection by TECH and ENG.
- Inspect Signal Pole Foundation** – DSI, TECH, ENG - including size, reinforcement cage, foundation conduit, bolt pattern, bolt orientation, and foundation height
- Inspect Conduit Trenches** – DSI - including depth, width, and location
- Inspect Controller and Service Cabinet Foundations** – DSI, TECH – Require approval prior to concrete and grounding
- Inspect Conduit, Pull Box, and Handhole Installations** – DSI, TECH – Handholes must be located on the lane lines. Check conduit/Pull Box sizes.
- Inspect Loop Installation** – TECH
- Inspect Trench Backfill** – DSI - including AC/PCC repair
- Inspect DLC Installation** – TECH
- Inspect Signal Pole Installation** – DSI, TECH
- Inspect Phase and Service Wire Installation** – TECH
- Inspect Signal Head Installation and Alignment** – TECH
- Request City Supplied Equipment** –TECH, ENG – requires 10 day notice and prepayment for equipment prior to contractor pick-up unless exempt (contact Engineering for invoice)
- Inspect Controller and Service Cabinet Installations** – TECH – DSI to notify the TECH 48 hours prior to the contractor's scheduled equipment pickup date.
- Inspect Pedestrian Push Button, Opticom, and Luminaire Installation** – TECH
- Inspect SIC Installation** - TECH

## PRIOR TO SIGNAL ACTIVATION

- Install/Verify Approved Signal Timing** - TECH
- 5 Day Functional Test** – TECH
- Flash Out Signal** – TECH
- Initiate QuicNet Communication** – TECH, ATMS
- Verify Final Striping** – DSI, TECH, ENG
- Signal Turn-On** – DSI, TECH, ENG

## POST SIGNAL ACTIVATION

- Verify all Signal Indications and Pedestrian Phases Operational** – TECH, ENG
- Monitor Signal Timing** – TECH, ENG
- Generate Signal Punch List** – TECH, ENG
- 1-Year Warranty Inspection** – DSI, TECH

**48 hour notice required for inspections, Functional testing, and Signal Turn-On without prior approval.**

RESTRICTIONS 10 DAYS PRIOR TO THANKSGIVING THROUGH JANUARY 3RD

WORK MAY BE ALLOWED: WEEKDAYS 9PM TO 11AM

NO WORK ALLOWED: WEEKDAYS 11AM TO 9PM  
WEEKENDS/HOLIDAYS

\*UNLESS OTHERWISE PERMITTED BY AN APPROVED TRAFFIC CONTROL PLAN

**LEGEND**

 RESTRICTED ROADWAYS

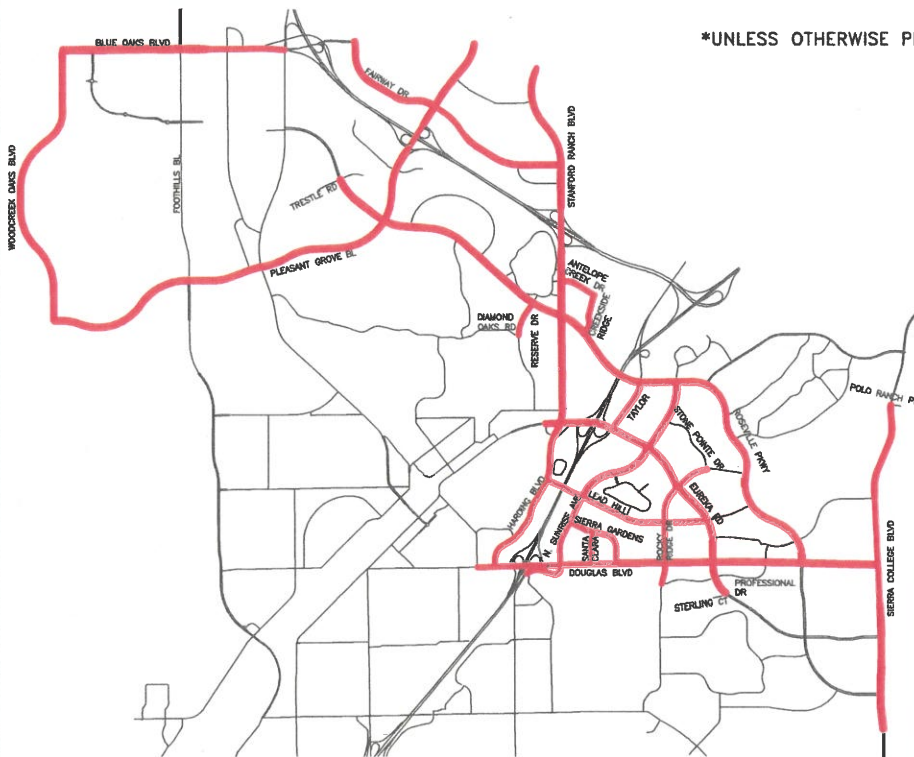

  
 JASON SHYKOWSKI  
 PUBLIC WORKS DIRECTOR

CITY OF <b>ROSEVILLE</b> CALIFORNIA	DEPARTMENT OF PUBLIC WORKS
<b>HOLIDAY TRAFFIC CONTROL                  RESTRICTIONS</b> (IN ADDITIONS TO CITY STANDARDS WORKING HOUR RESTRICTIONS)	
SCALE: NONE REVISED: DEC 20, 2022 DRAWN BY: J PASTOR APPROVED BY: J CERVANTES	TS-23

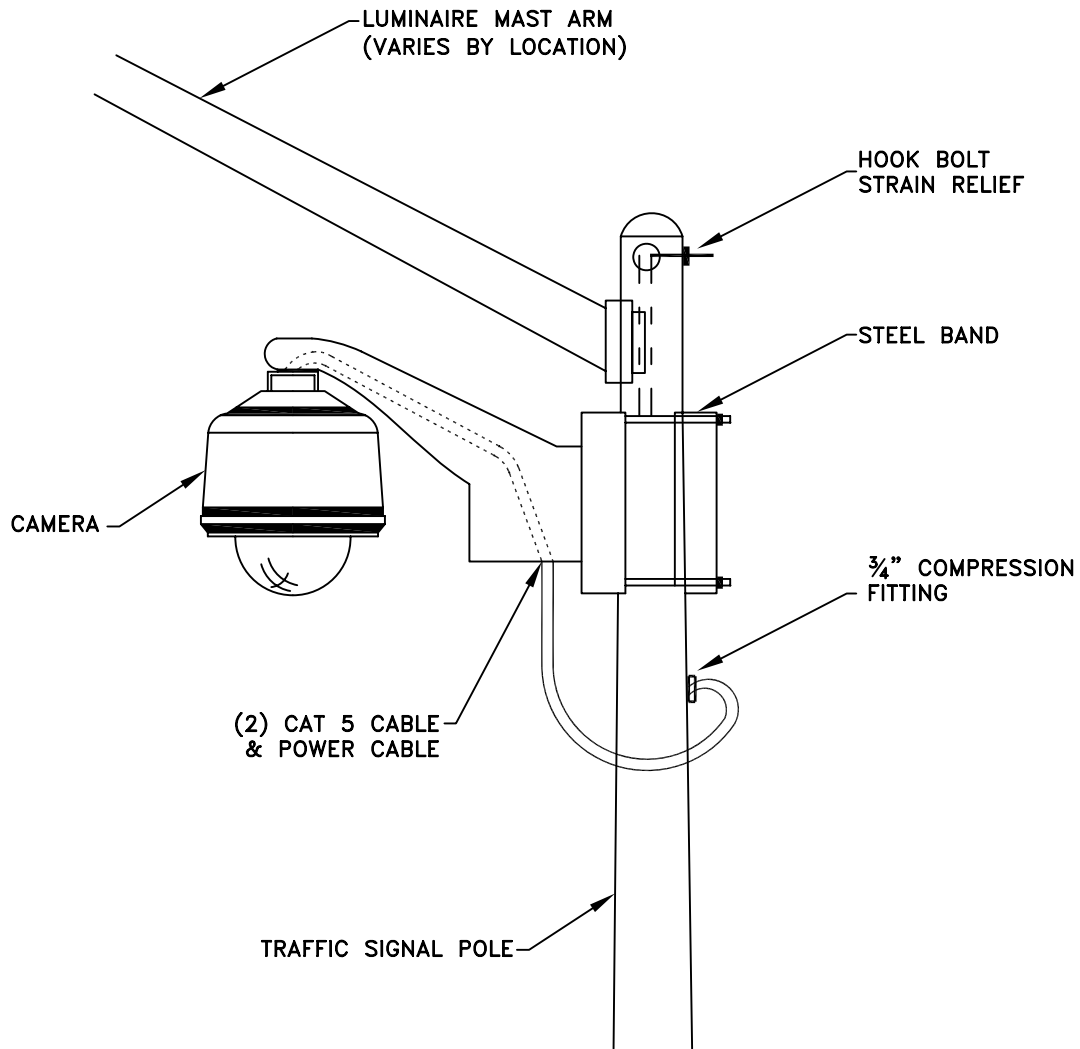

CCTV MOUNTING ASSEMBLY ORIENTATION

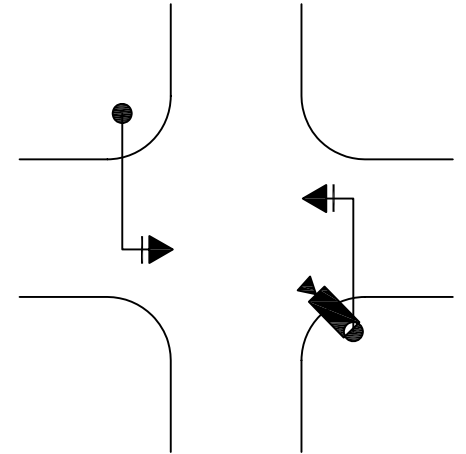

THE ROTATION OF THE CCTV MOUNT SHALL BE ALIGNED TO A POINT AT THE TRAFFIC SIGNAL POLE ON THE DIAGONALLY OPPOSITE CORNER.

RHON HERNDON  
PUBLIC WORKS DIRECTOR



DEPARTMENT OF  
PUBLIC WORKS

CCTV MOUNTING ASSEMBLY



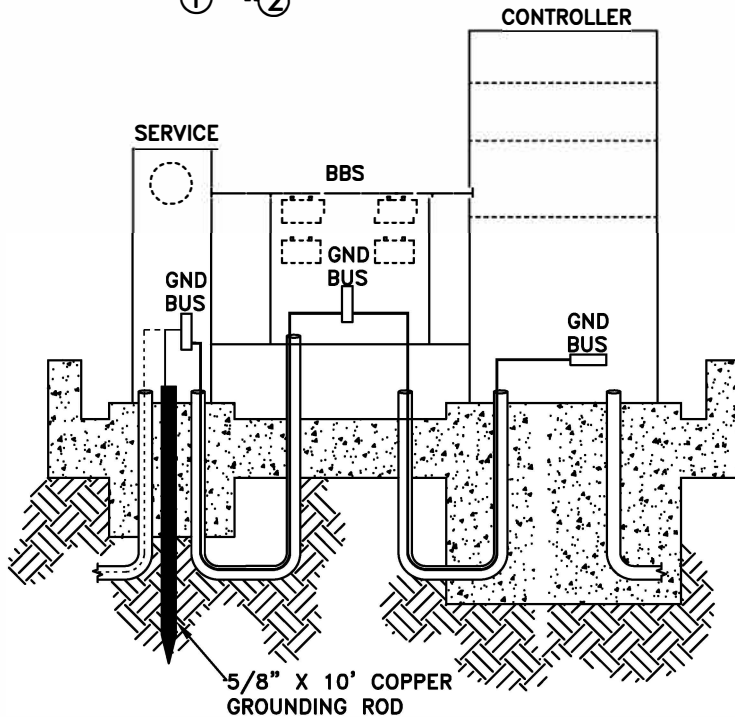
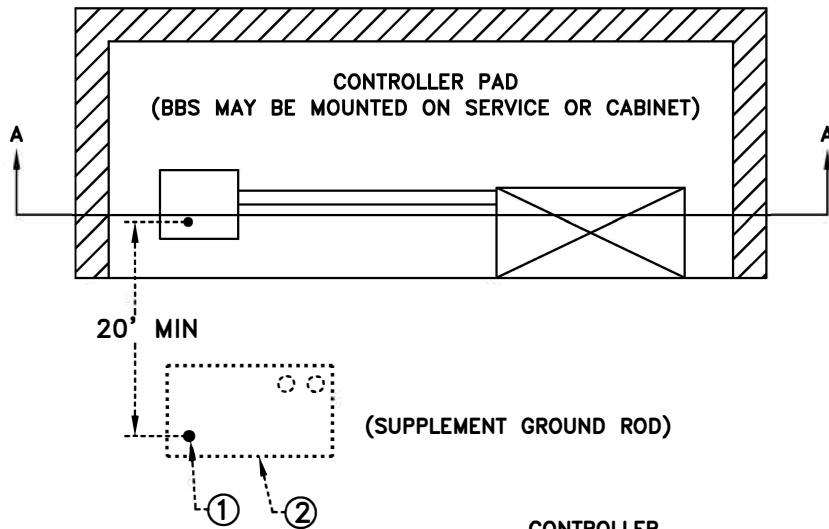

SCALE: NONE  
REVISED: JANUARY 1, 2010  
DRAWN BY: J MCKINNEY  
APPROVED BY: RHON HERNDON

TS-24



SECTION A

**LEGEND**

-   $\phi 5/8"$  x 10' GROUNDING ROD
-  CONDUIT
-  GROUNDING ELECTRODE CONDUCTOR #6 STRANDED WITH THW INSULATION (COLOR GREEN)
-  EQUIPMENT GROUNDING CONDUCTOR - #8 STRANDED WITH THW INSULATION (COLOR GREEN)

**NOTE (SUPPLEMENTAL GROUND ROD):**

THE COMBINED GROUND ROD RESISTANCE BETWEEN THE SERVICE AND N-36 PULLBOX WITH EXTENSION SHOULD BE LESS THAN 5Ω. IF RESISTANCE IS GREATER THAN 5Ω, A THIRD GROUND ROD MAY BE NECESSARY (SEE CITY STAFF FOR FURTHER DIRECTION).

**LEGEND (SUPPLEMENTAL GROUND ROD)**

1. 5/8"X10'(L) GROUND ROD SHALL BE INSTALLED A MINIMUM OF 20' FROM SERVICE GROUND ROD. GROUND ROD TO BE PLACED ON STREET SIDE CORNER OF PULL BOX. GROUNDING ELECTRODE CONDUCTOR SHALL BE CONTINUOUS TO THE SERVICE GROUND ROD AND CONTINUE TO THE SERVICE GROUND BUS.
2. THE SUPPLEMENTAL GROUND ROD SHALL BE LOCATED IN A N-36 PULLBOX WITH EXTENSION THAT HAS A HORIZONTAL SEPARATION OF 20' OR GREATER FROM THE SERVICE GROUND ROD.



DEPARTMENT OF  
PUBLIC WORKS

CONTROLLER/SERVICE  
GROUNDING DIAGRAM

SCALE: NONE  
REVISED: JANUARY 01, 2018  
DRAWN BY: J PASTOR  
APPROVED BY: J CERVANTES

TS-25

  
RHON HERNDON  
PUBLIC WORKS DIRECTOR

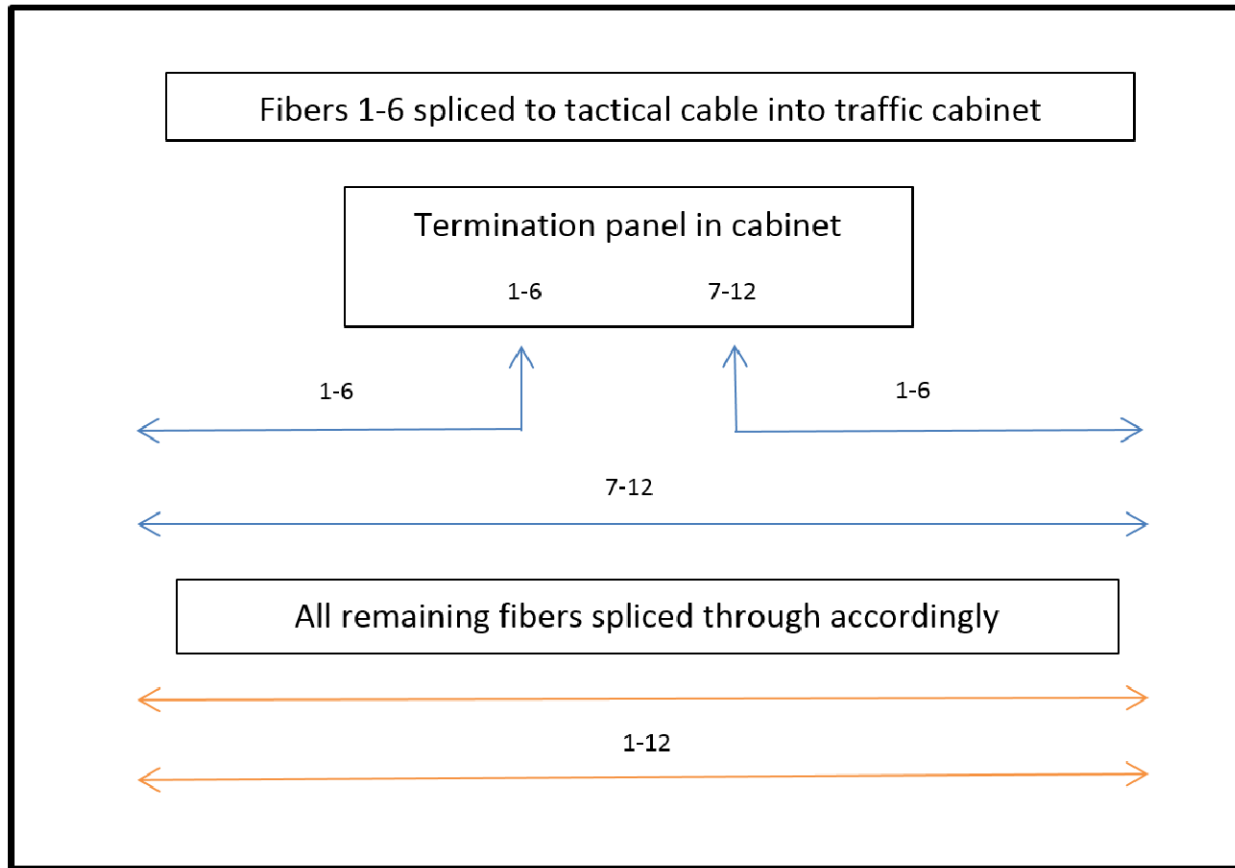

RHON HERNDON  
PUBLIC WORKS DIRECTOR

Materials required for Type 1 splice:

Coyote LCC splice enclosure and splice trays (P.N. COYFCC-F006) or Coyote Runt splice enclosure and splice trays (P.N. 8006671).  
(City to determine which enclosure to use.)

Minimum pull box size for splice location is N-36.  
Corning tactical fiber optic cable for local cabinet – see City approved equipment list.  
Cabinet termination panel Corning SPH-01P housing with CCH-CP12-A9 panel.

	DEPARTMENT OF PUBLIC WORKS
<h2 style="margin: 0;">TYPE 1 FIBER SPLICE</h2>	
SCALE: NONE REVISED: MAR. 24, 2015 DRAWN BY: T. ZAMORA APPROVED BY: RHON HERNDON	<b>TS-26</b>

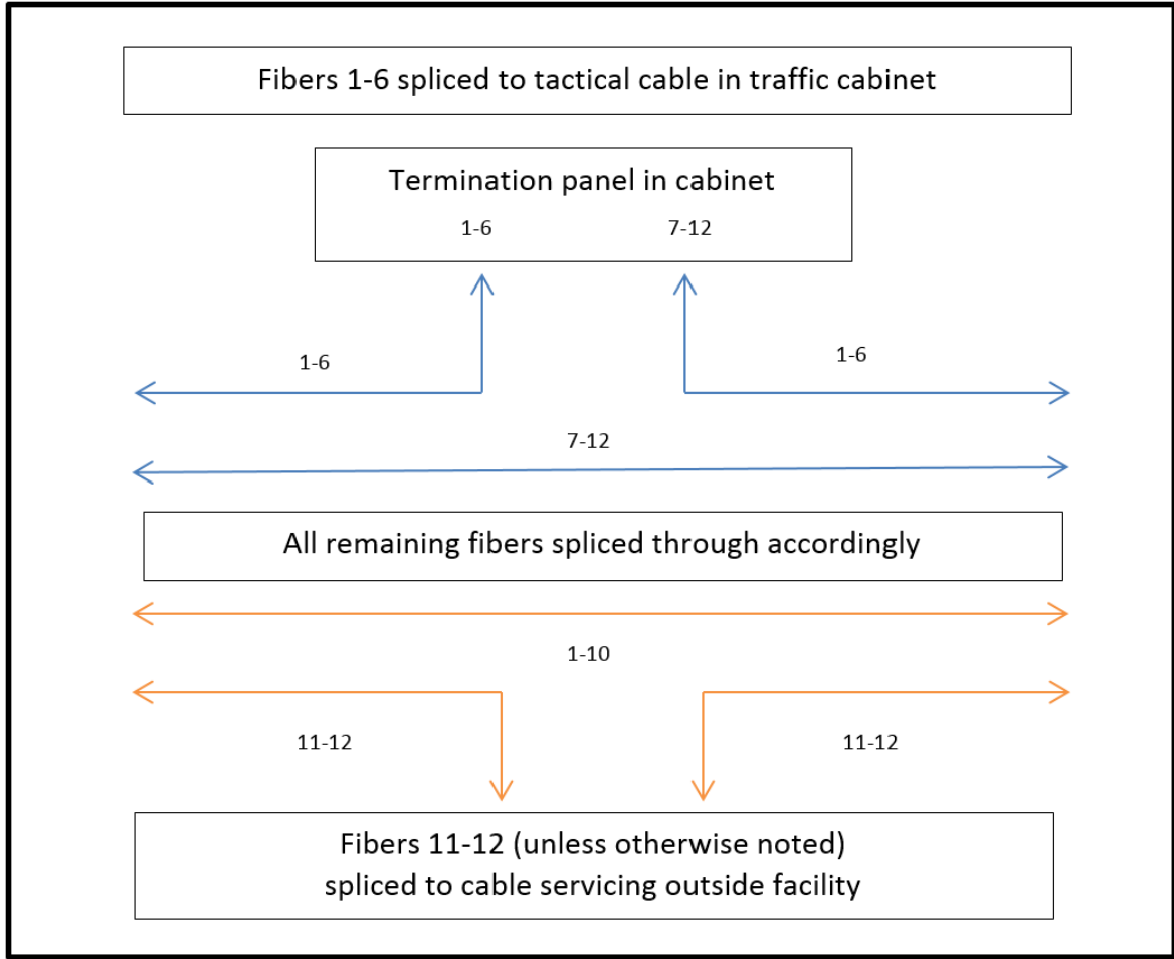

*RHON HERNDON*

RHON HERNDON  
PUBLIC WORKS DIRECTOR

Materials required for Type 2 splice:

Coyote LCC splice enclosure and splice trays (P.N. COYFCC-F006) or Coyote Runt splice enclosure and splice trays (P.N. 8006671).  
(City to determine which enclosure to use.)

Minimum pull box size for splice location is N-36.  
Corning tactical fiber optic cable for local cabinet – see City approved equipment list.  
Cabinet termination panel Corning SPH-01P housing with CCH-CP12-A9 panel.

	DEPARTMENT OF PUBLIC WORKS
<h3>TYPE 2 FIBER SPLICE</h3>	
SCALE: NONE REVISED: MAR. 24, 2015 DRAWN BY: T. ZAMORA APPROVED BY: RHON HERNDON	<b>TS-27</b>

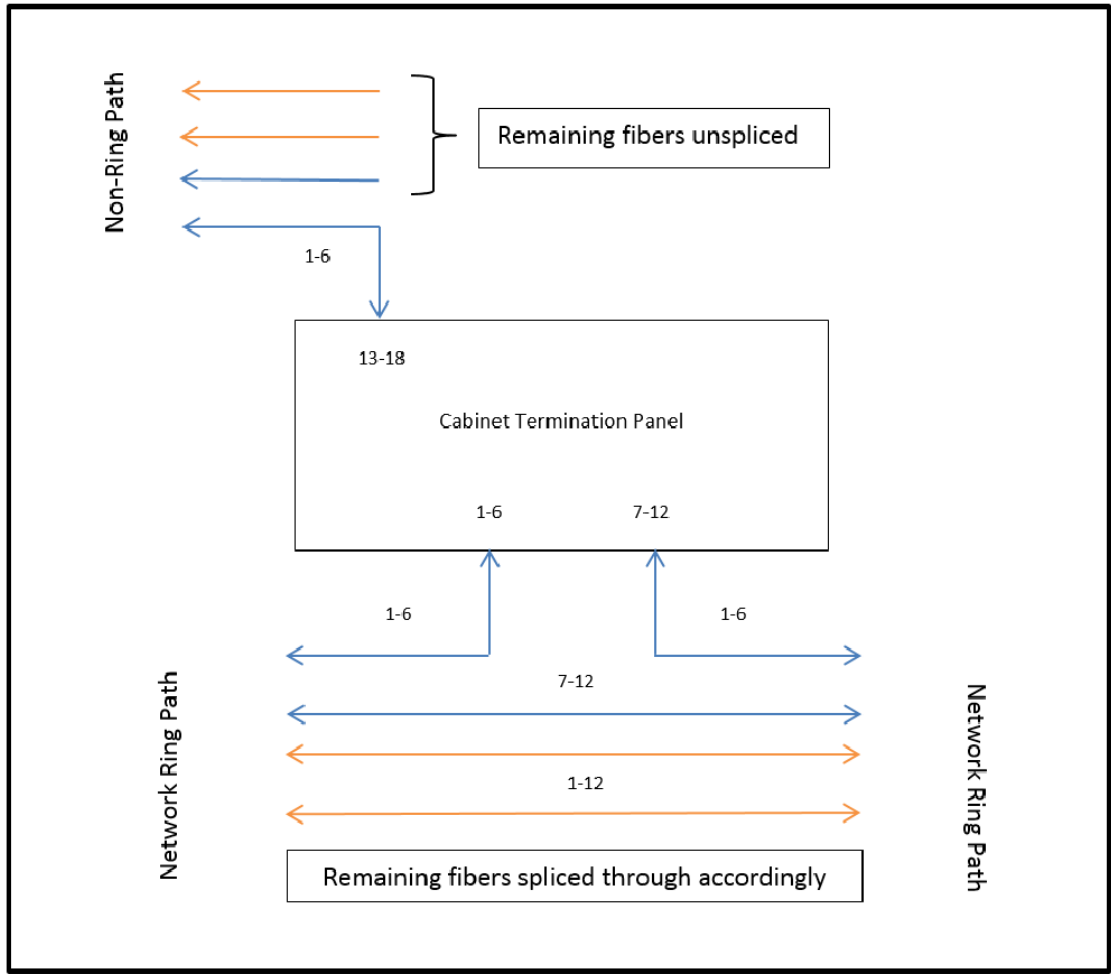

*RH Herndon*

RHON HERNDON  
PUBLIC WORKS DIRECTOR

Materials required for Type 3 splice:

Coyote Runt splice enclosure and splice trays (P.N. 8006671).  
 Minimum pull box size for splice location is N-36.  
 Corning tactical fiber optic cable for local cabinet – see City approved equipment list.

Cabinet termination panel(s):

Corning SPH-01P housing (2 ea.) with CCH-CP12-A9 panels or  
 Corning SPH-01P housing with CCH-CP24-A9 panel.  
 (City to determine which panel(s) to use.)

		DEPARTMENT OF PUBLIC WORKS
<h3>TYPE 3 FIBER SPLICE</h3>		
SCALE: NONE REVISED: MAR. 24, 2015 DRAWN BY: T. ZAMORA APPROVED BY: RHON HERNDON		TS-28

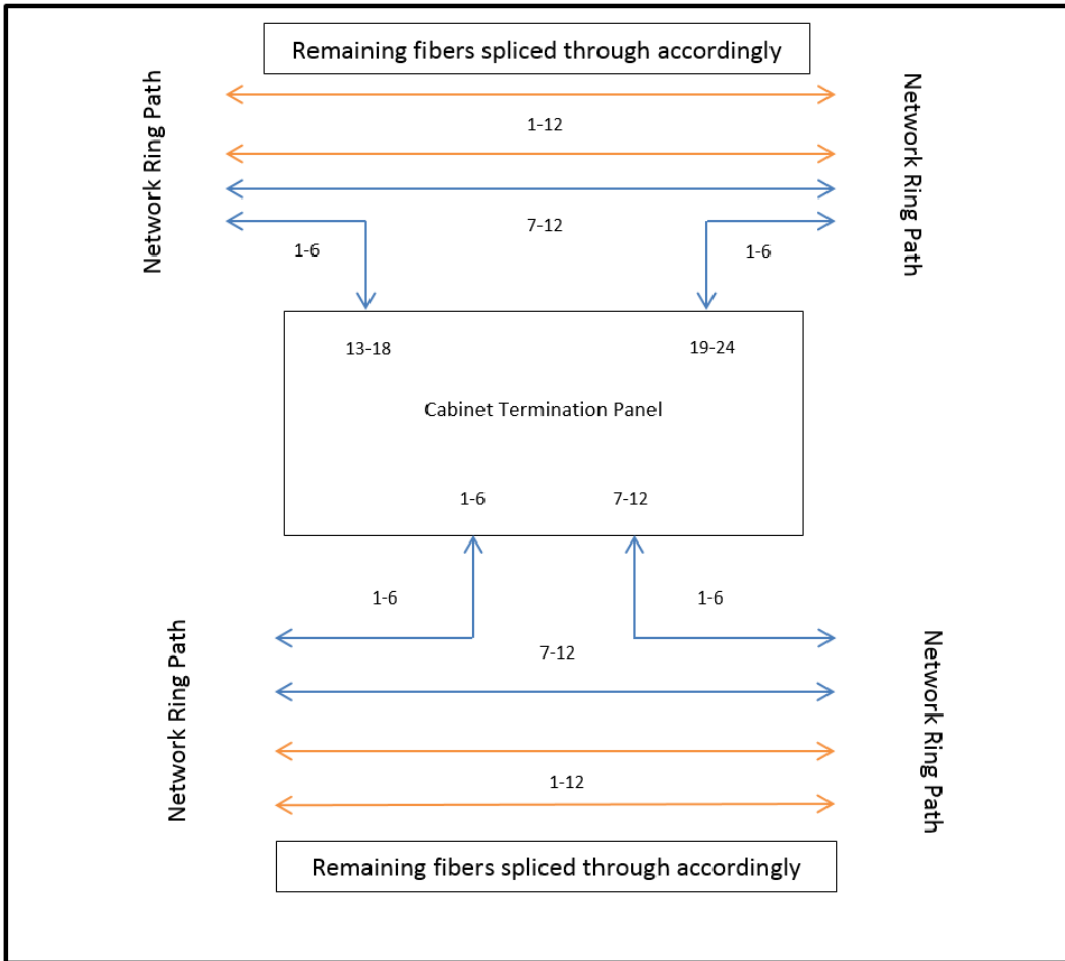

*RHON HERNDON*

RHON HERNDON  
PUBLIC WORKS DIRECTOR

Materials required for Type 4 splice:

Coyote Runt splice enclosure and splice trays (P.N. 8006671) or  
Coyote Dome splice enclosure (9.5" x 19") and splice trays (P.N. COYD-919B-000).  
(City to determine enclosure to use.)

Minimum pull box size for splice location is N-48 with extension.  
Corning tactical fiber optic cable for local cabinet – see City approved equipment list.

Cabinet termination panel(s):

Corning SPH-01P housing (2 ea.) with CCH-CP12-A9 panels or  
Corning SPH-01P housing with CCH-CP24-A9 panel.  
(City to determine which panel(s) to use.)

		DEPARTMENT OF PUBLIC WORKS
TYPE 4 FIBER SPLICE		
SCALE: NONE REVISED: MAR. 24, 2015 DRAWN BY: T. ZAMORA APPROVED BY: RHON HERNDON		TS-29



- Steady Red Arrow - Drivers turning left must stop and wait
- Steady Yellow Arrow - Stop, if you can do so safely
- Flashing Yellow Arrow - Proceed with left turn after yielding to oncoming traffic
- Steady Green Arrow - Proceed with left turn

**SECONDARY**

**PRIMARY**

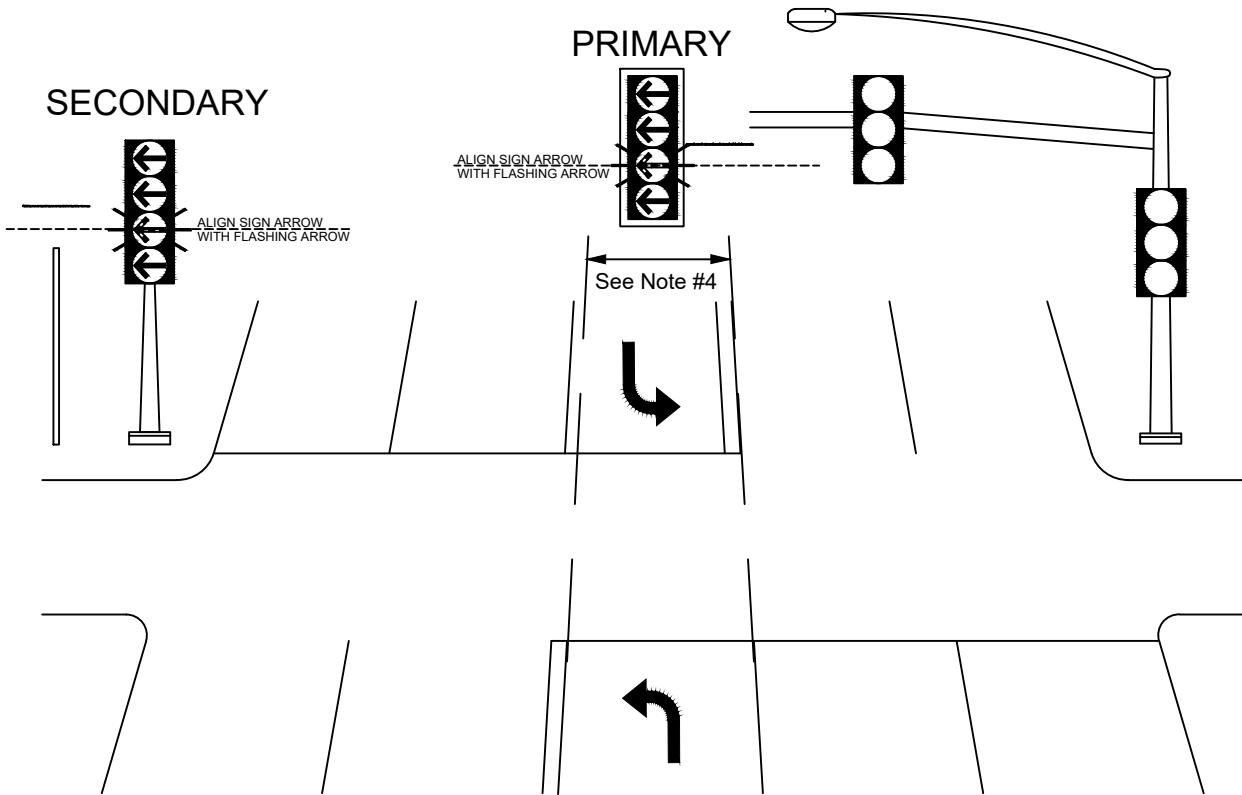

DETAIL A

NOTES:

1. Shall conform to current CA MUTCD guidelines.
2. Sight distance (SD) should meet AASHTO/FHWA recommended intersection SD for permissive left turns.
3. Number of opposing thru lanes  $\leq 3$ .
4. Implemented at Single Left turn lanes only.
5. Cannot be implemented if traffic signal has split phased operation.
6. Sign - "Left Turn Yield on Flashing" - Yellow Arrow Symbol, minimum size 24"x30" 36"x48", white - background, black-letters, yellow - arrow symbol.
7. MAS-4B mounting type shall be used for the signal mast arm 4-section head.
8. TV mounting type shall be used for the 1-b pole 4-section head.
9. Optional 2nd sign for "far-side" 1B. Sign to be angled towards corresponding left-turn lane. Sign location TBD in field.
10. Yellow reflective tape shall be installed on overhead signal head (outlined)
11. Tee-intersections: Sign placard (18"x36" with 4" letter height) as shown on Detail A shall be installed underneath a Signal Ahead (W3-3) sign on the approach of the major roadway that does not have a left-turn/ flashing yellow arrow.

*Jason Shykowski*  
 JASON SHYKOWSKI  
 PUBLIC WORKS DIRECTOR



DEPARTMENT OF  
PUBLIC WORKS

STANDARD INSTALLATION OF FLASHING  
YELLOW ARROW PROTECTED/PERMISSIVE  
TRAFFIC SIGNAL

SCALE: NONE  
 REVISED: APRIL 01, 2024  
 DRAWN BY: J PASTOR  
 APPROVED BY: J CERVANTES

TS-30

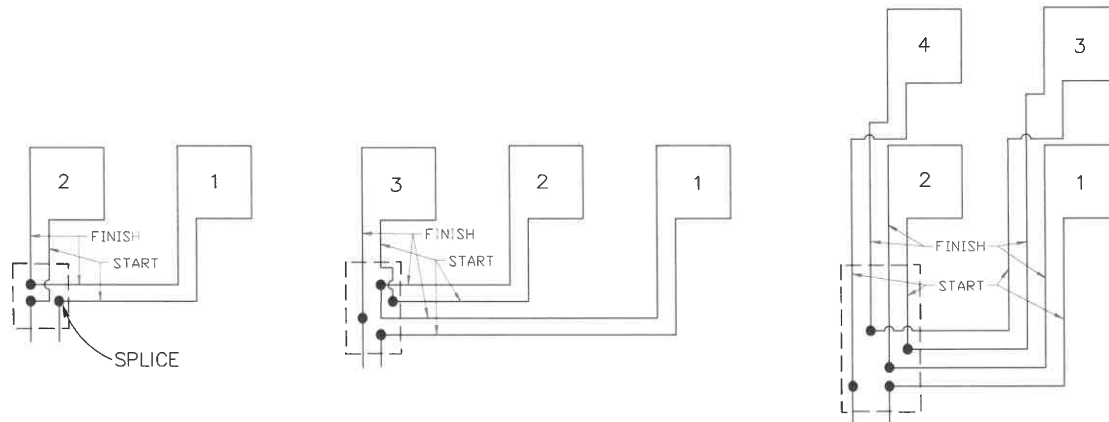

**TYPICAL LOOP CONNECTIONS**

Dashed lines represent the pull box

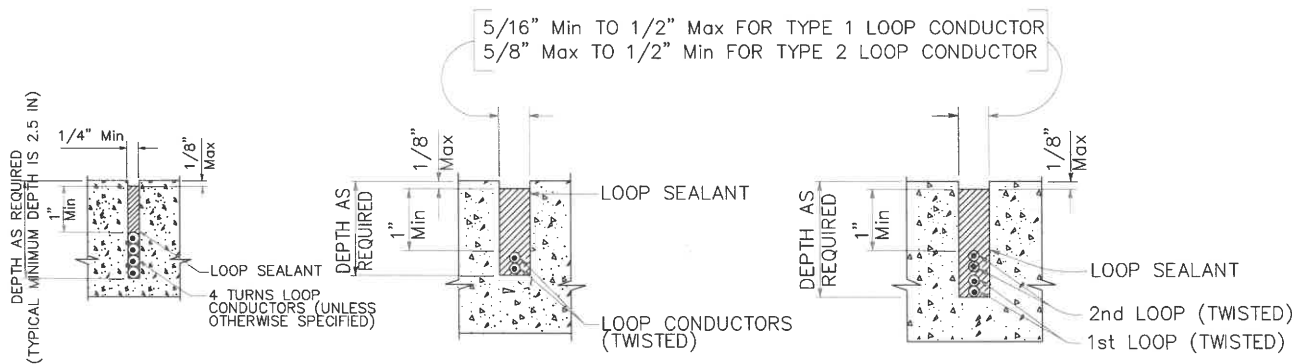

**TYPICAL SAW CUT DETAILS**

*Jason Shykowski*  
**JASON SHYKOWSKI**  
**PUBLIC WORKS DIRECTOR**

 <b>CITY OF ROSEVILLE</b> CALIFORNIA	<b>DEPARTMENT OF PUBLIC WORKS</b>
--	-----------------------------------

**LOOP DETAIL: CONNECTIONS AND SAW CUT**

ALL LOOPS WOUND CLOCKWISE.  
 ALL LOOPS SPLICED IN SERIES.

SCALE: NONE  
 REVISED: NOVEMBER 2023  
 DRAWN BY: R. YAKIMCHUK  
 APPROVED BY: J CERVANTES

TS-31